

**502A-T  
4-20 mA THERMOCOUPLE  
TRANSMITTER**

10635ML-01

DXR0994BXG2B

© Copyright 1994, NEWPORT ELECTRONICS, INC. All rights reserved.

This documentation may not be copied, photocopied, reproduced, translated, or reduced to any electronic medium or machine-readable form, in whole or in part, without prior written consent of NEWPORT ELECTRONICS, INC.

REV	ECO NO.	DATES	BY	CHK
B	5336	3/8/87	DR	ISH

## TABLE OF CONTENTS

1.0 GENERAL INFORMATION . . . . .	1
Accuracy and Stability . . . . .	1
Adaptability/Turndown . . . . .	1
Electrical Isolation . . . . .	1
Shock Resistance . . . . .	1
Waterproof/RFI/Thermal Gradient Resistant Case . . . . .	1
Mounting Adaptability . . . . .	1
2.0 SPECIFICATIONS . . . . .	2
Input . . . . .	2
Output . . . . .	2
Accuracy . . . . .	2
Environmental . . . . .	2
Mechanical . . . . .	2
3.0 MECHANICAL ASSEMBLY AND INSTALLATION . . . . .	3
Unpacking and Inspection . . . . .	3
Safety Considerations . . . . .	3
Optional Adapters for Mounting . . . . .	6
Bulkhead and TR2/2TK Relay Track Mounting Procedure . . . . .	6
DIN EN-50 022 Relay Track Mounting Procedure . . . . .	7
External Explosion-Proof Housing Mounting Procedure . . . . .	8
4.0 POWER AND SIGNAL INPUT CONNECTIONS . . . . .	9
5.0 CONFIGURATION . . . . .	10
Tools and Equipment . . . . .	10
Calibration Procedure, Ambient Temperature . . . . .	10
Calibration Procedure, Ice-Point Cell . . . . .	12
Pin Assignments . . . . .	16
Calibration Formula . . . . .	16
6.0 DRAWINGS . . . . .	17
 ILLUSTRATIONS	
Figure 3-1 Exploded View of Model 502A . . . . .	4
Figure 3-2 Case Dimensions . . . . .	5
Figure 3-3 Bulkhead and Track Mounting . . . . .	6
Figure 3-4 DIN Track Mounting . . . . .	7
Figure 3-5 Spring Retainer for Explosion-Proof Housing . . . . .	8
Figure 4-1 Power Input Connections . . . . .	9
Figure 5-1 Calibration Setup Using Ambient Temperature . . . . .	10
Figure 5-2 Calibration Setup Using Ice-Point Cell . . . . .	12
Figure 5-3 Jumper Diagram . . . . .	16
Figure 6-1 502A Preamp Block Diagram . . . . .	17
Figure 6-2 502A Postamp Block Diagram . . . . .	17
Table 5-1 Type T Thermocouple Reference Table . . . . .	14
Table 5-2 Celsius Temperature Ranges Obtained with Jumpers . . . . .	15
 APPENDICES	
Appendix A Transmitter Accuracy Factors . . . . .	18

The 502A-T two-wire transmitter takes in millivolt signals generated by a type T thermocouple, provides cold (reference) junction compensation, amplification, common-mode isolation, and controls the current drawn from a 9-to-50 V dc source to produce the 4-to-20 milliampere output signal.

Common-mode voltage between the input thermocouple and the output current circuit is tested at 1500 V rms. As much as 750 ohms dropping resistance or 625 ohms in series with a loop-powered indicator (Newport model 508A) may be used in the power leads of the 502A when the unit is energized from a 24 V dc source. This is because of the small compliance voltage needed by the unit. Accidental overloads of over one minute by 120 V rms on either input or output leads do not damage the 502A.

#### 1.1 ACCURACY AND STABILITY

The 502A-T has tailored resistance values installed to provide curvilinear cold-junction compensation matched to the NBS or IEC type T thermocouple table. Selected bridge resistors in a temperature-sensing bridge also provide cancellation of Span temperature effects. The unit is certified for accuracy from -40 to +85°C (-40 to +185°F) through verification of high-ambient-temperature compensation points.

#### 1.2 ADAPTABILITY/TURNDOWN

The Span of the 502A-T can be ranged anywhere from 50 to 400°C by selection of one of four jumper positions, with fine tuning provided by a multiturn, top-accessible potentiometer. Sixteen Zero steps, also provided by 502A-T jumpers, allow placement of the 4.00 mA output temperature anywhere from -50 to 350°C, with fine tuning provided by another top-accessible, multiturn potentiometer. This 502A turndown capability exceeds that of any other known transmitter.

#### 1.3 ELECTRICAL ISOLATION

502A input (thermocouple and shield) and output (DC power) barrier strips accept wires up to two millimeters in diameter (13 gauge), and are mechanically isolated from each other to prevent input/output wiring contact during installation.

#### 1.4 SHOCK RESISTANCE

Lightweight 502A circuit boards are formed into a rigid box structure and firmly soldered and epoxied to the case top. The circuit-board box is doubly coated with RTV silicone for environmental protection. When installed in the rugged, die-cast case, the 502A can withstand the shock of a 6-foot drop onto a hard surface (although scarring of the case and/or deformation of the plastic cover can occur).

#### 1.5 WATERPROOF/RFI/THERMAL GRADIENT RESISTANT CASE

The 502A case is made from Zamac (zinc alloy), coated with polyurethane, and gasketed with fluorosilicone. Fluorosilicone plugs protect the top-access Span and Zero potentiometers. An optional opaque top cover shields the barrier strips from uneven heating or cooling in exposed environments.

#### 1.6 MOUNTING ADAPTABILITY

The small size of the 502A (less than 75 mm or 3 in. outside diameters) permits snap mounting into the American 8TK2 relay track or wall mounting in confined areas. With a bulkhead adapter, the 502A can be snap mounted into the larger American TR2/2TK relay track or wall mounted by rotating the adapter 90 degrees. With the use of the rail clamp adapter, the 502A may be mounted onto the narrow DIN EN-50-022 relay track. Using the spring retainer option, the 502A can be mounted into explosion-proof housings.

## 2.1 INPUT

Configuration:	Isolated input
Thermocouple type:	T (Copper/Constantan)
Input impedance:	5 MOhms
Thermocouple break-detect current:	50 nA max
Burnout indication:	Selectable up or down overscale
Thermocouple lead resistance:	Up to 500 ohms for specified performance
Normal mode rejection:	60 dB at 50/60 Hz with 100 mV input
Common mode voltage, input to case or output:	2100 V peak per high pot. test; 354 V peak per IEC spacing
Common mode rejection, input to case or output:	100 dB min from DC to 60 Hz
Overvoltage protection:	120 V ac max/1 min exposure

## 2.2 OUTPUT

Linear range:	4 to 20 mA dc
Compliance (supply-voltage):	9 to 50 V dc
Overvoltage protection:	120 V ac
Reverse polarity protection:	400 V peak
Common mode voltage, output to case or input:	2100 V peak per high pot. test; 354 V peak per IEC spacing
Common mode rejection, output to case or input:	100 dB min from DC to 60 Hz

## 2.3 ACCURACY

Hysteresis and repeatability:	Within $\pm 0.2^{\circ}\text{C}$ $\pm 0.1\%$ of Span
Conformity, 50°C Span:	$\pm 0.5^{\circ}\text{C}$
Six month stability:	Within $\pm 0.2^{\circ}\text{C}$ $\pm 0.2\%$ of 4 mA temperature
Power supply effect:	Within $\pm 0.005\%/V$
Ambient temperature effect for 50°C change:	ZERO Error: $\pm 0.04^{\circ}\text{C}/^{\circ}\text{C}$ Typical SPAN Error: $\pm 0.03^{\circ}\text{C}/^{\circ}\text{C}$ Typical

## 2.4 ENVIRONMENTAL

Operating temperature:	-40 to 85°C
Storage temperature:	-55 to 125°C
Humidity:	To 100%
Vibration:	1.52 mm (.06 in) double amplitude, 10-80 Hz cycled
Shock:	55g, half-sine, 9-13 msec duration, 6' drop to hard surface
Watertight pressure limit:	35 kPa (5 psi)
Mounting position:	Any

## 2.5 MECHANICAL

Case material:	Zamac (zinc alloy), polyurethane-coated, fluorosilicone-gasketed
Weight:	300 g (10 oz)
Diameter:	74 mm (2.9 in)
Height (including barriers):	52 mm (2.1 in)
Connections:	#6 screws with wire clamps

10635ML-01

### 3.0 MECHANICAL ASSEMBLY AND INSTALLATION

#### 3.1 UNPACKING AND INSPECTION

Your 502A-T was systematically inspected and tested, then carefully packed before shipment. Unpack the instrument and inspect for shipping damage. If possible, remove the casing and visually inspect the internal circuitry. Notify the freight carrier immediately if damage exists.

Each package includes an assembled transmitter and an owners' manual. If any items are not according to your order, contact your local distributor or Newport Electronics.

#### 3.2 SAFETY CONSIDERATIONS

As delivered from the factory/distributor, this instrument complies with required safety regulations. To prevent electrical or fire hazard and to ensure safe operation, please follow the guidelines below.

**VISUAL INSPECTION:** Do not attempt to operate the unit if damage is found.

**MOUNTING:** Observe the mounting instructions in the following pages, as applicable.

**POWER VOLTAGE:** Verify that the instrument is connected for the power voltage rating that will be used (9-50 V dc). If not, make the required changes as indicated in Section 4.

**POWER WIRING -** This instrument has no power-on switch; it will be in operation as soon as the power is connected.

**SIGNAL WIRING -** Do not make signal wiring connections or changes when power is on. Make signal connections before power is applied. If connection changes are required, first disconnect the power.

**EXERCISE CAUTION -** As with any electronic instrument, high voltage may exist when attempting to install, calibrate, or remove parts of the transmitter.

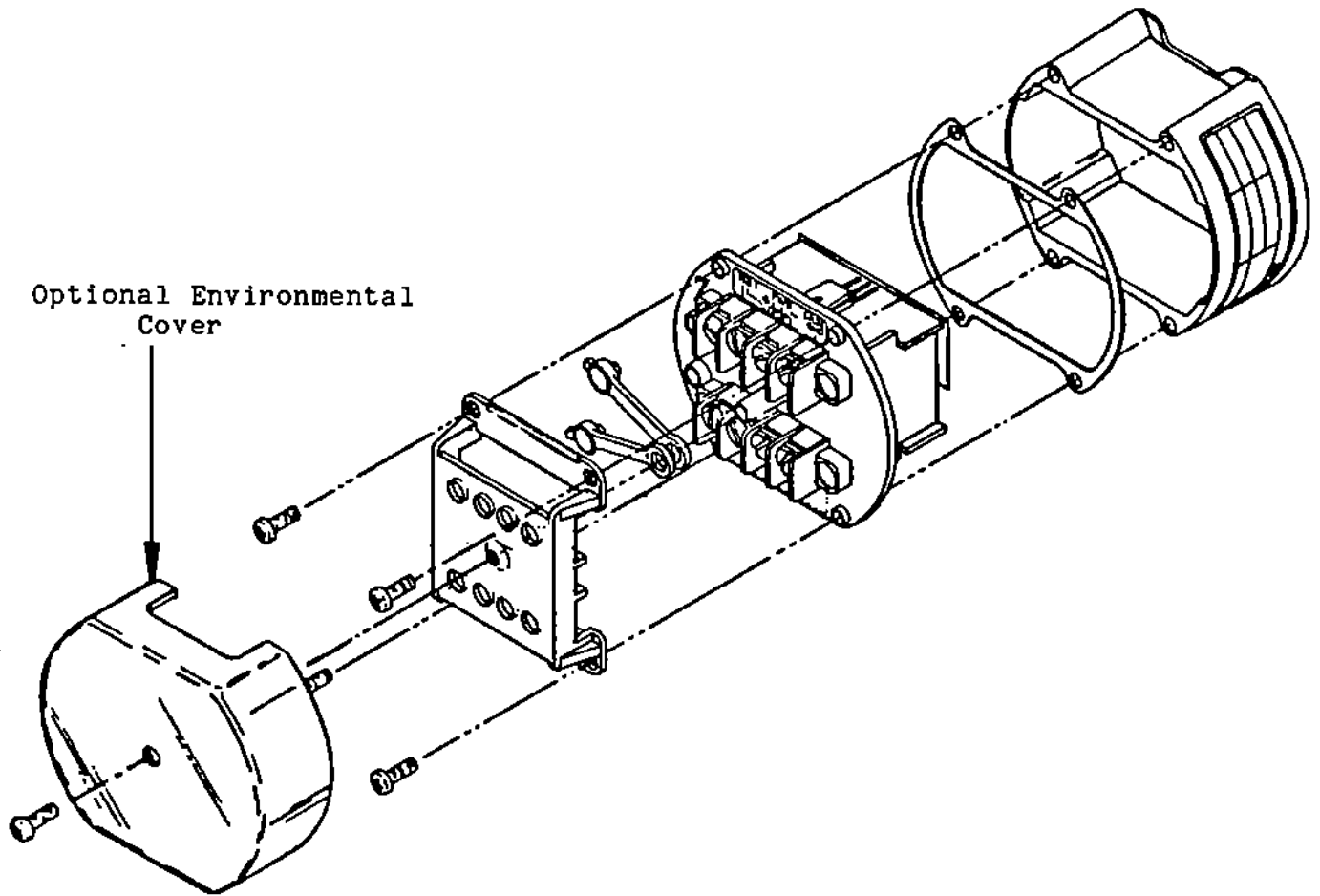
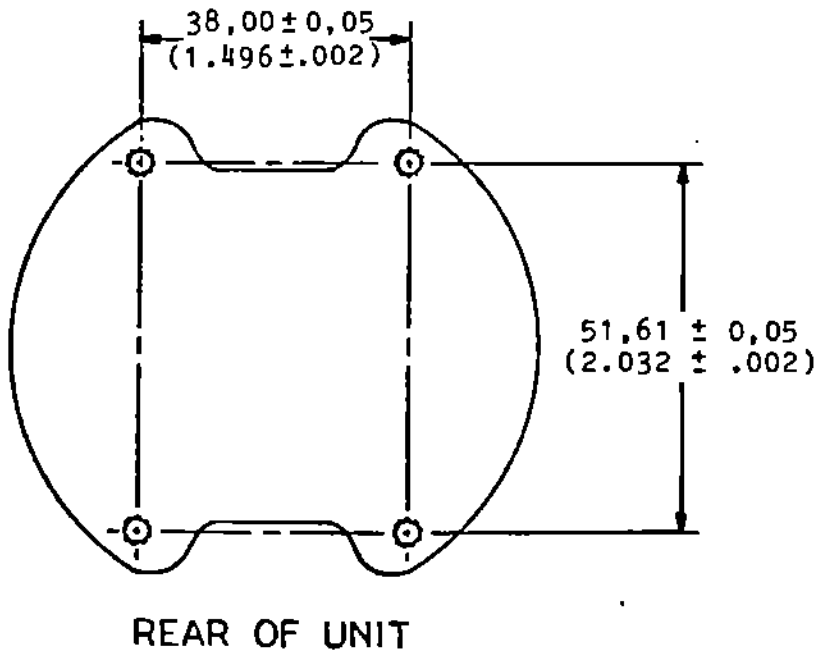
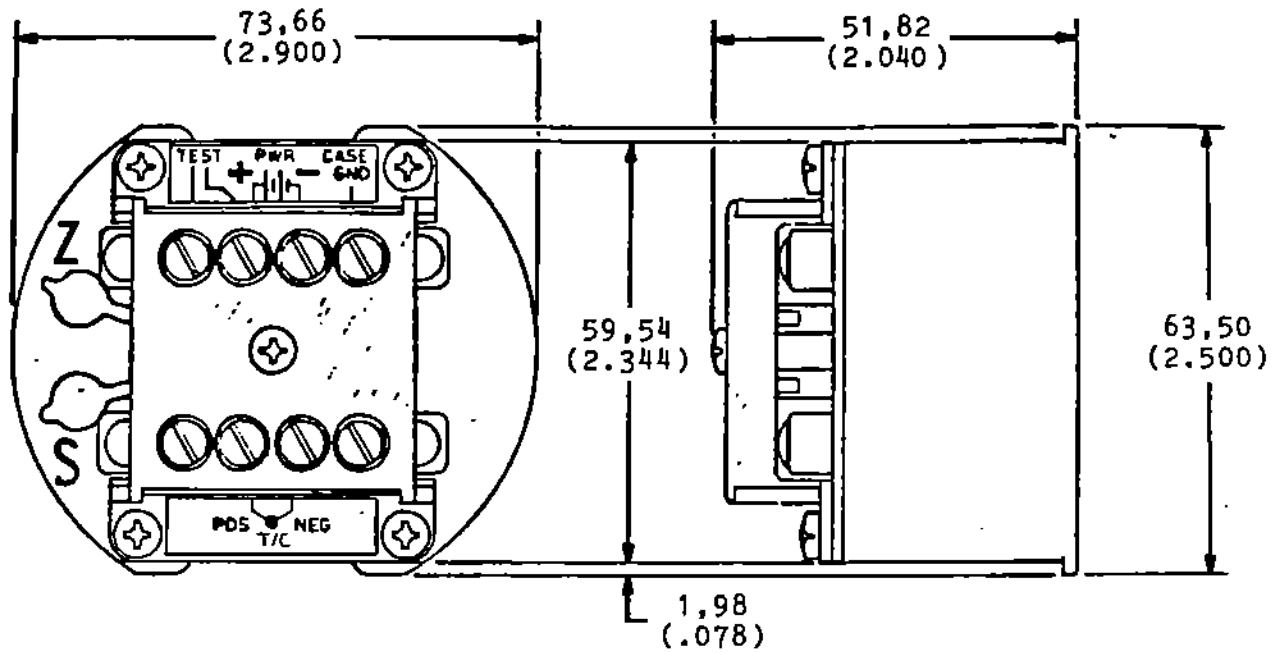

Figure 3-1 Exploded View of Model 502A



Four tapped holes with #6-32 screw threads on the rear of the case provide behind-the-wall access for bulkhead mounting; flanges on the rear of the case snap into the American 8TK2 rail for track mounting.

Figure 3-2 502A Case Dimensions

### 3.3 OPTIONAL ADAPTERS FOR MOUNTING

The following optional adapters provide various mounting choices:

- a. Adapter plate for either front-screw-entry surface mount or TR2/2TK relay track mount. See Figure 3-3.
- b. Rail clamp for DIN EN-50-022 relay track mount. See Figure 3-4.
- c. Spring retainer for explosion-proof housings that have internal diameters of 76.4 to 88.9 mm (3.0 to 3.5 in.). See Figure 3-5.

For ordering purposes, the options are identified as follows:

Adapter plate	MAT1
Rail Clamp	MDT1
Spring Retainer for Explosion-proof or Waterproof housing	MXS1
Explosion-proof/ Waterproof housing	EPH (Includes MXS1)

### 3.4 SURFACE AND TR2/2TK RELAY TRACK MOUNTING PROCEDURE

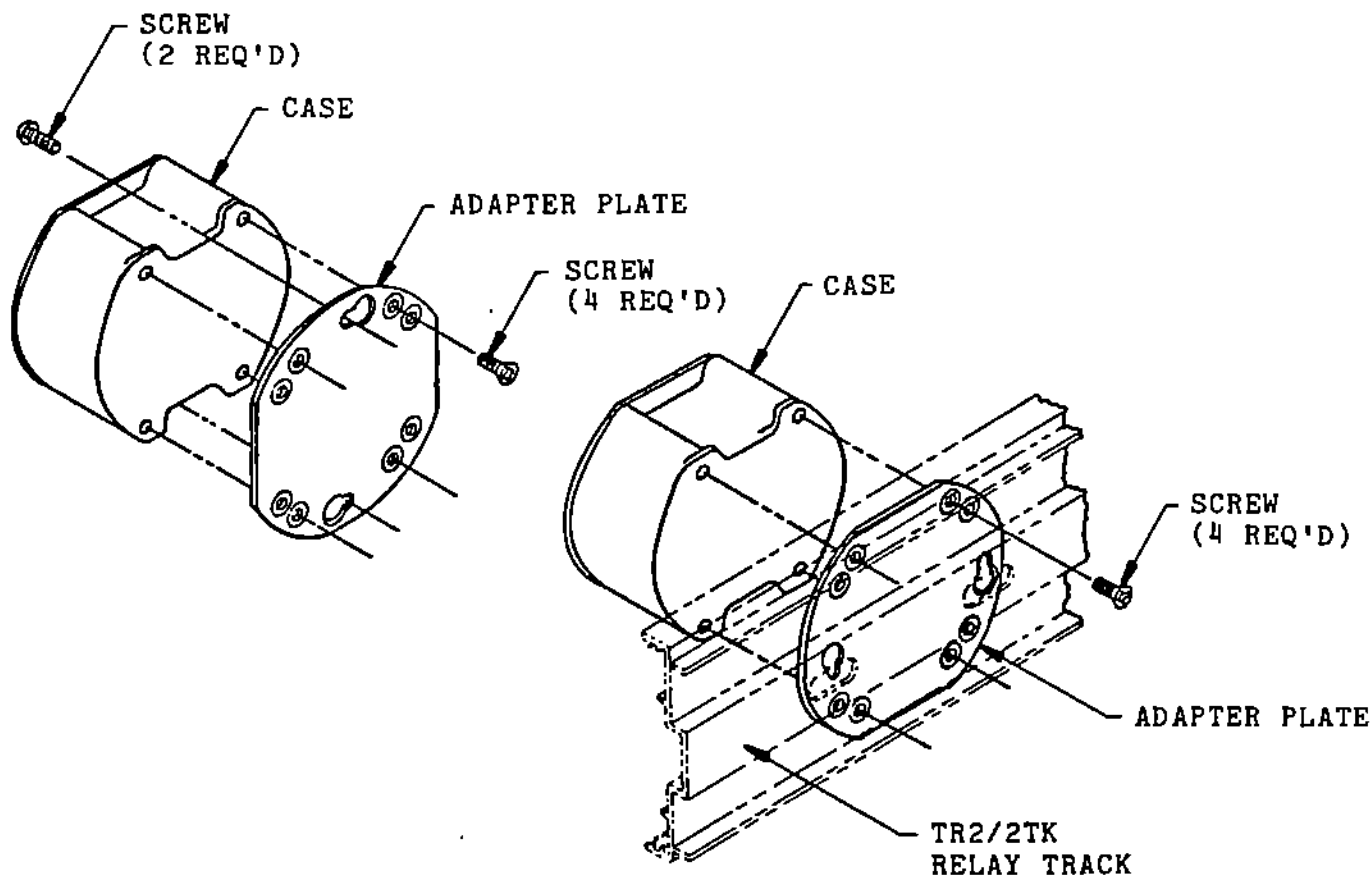
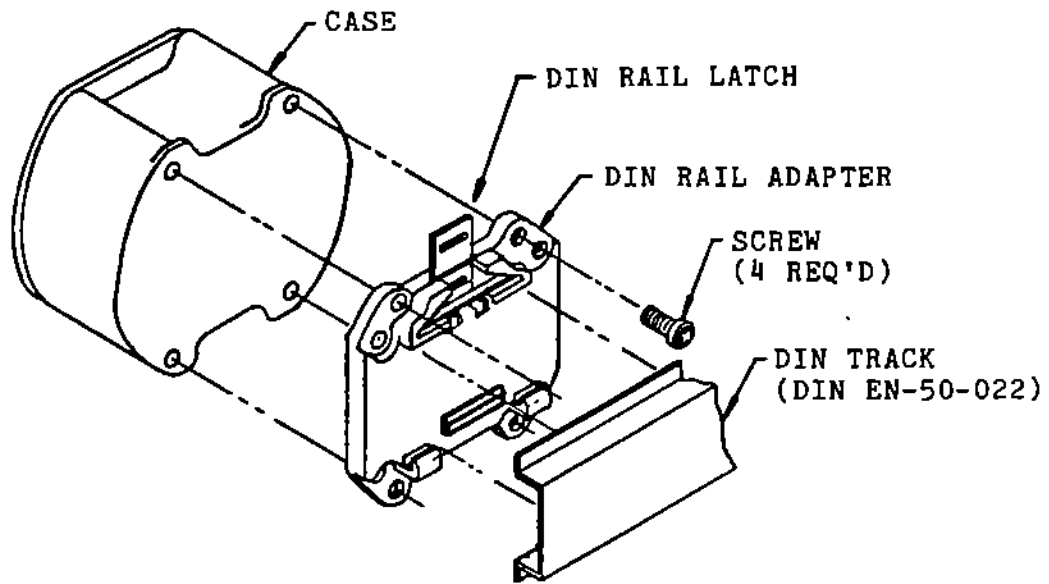
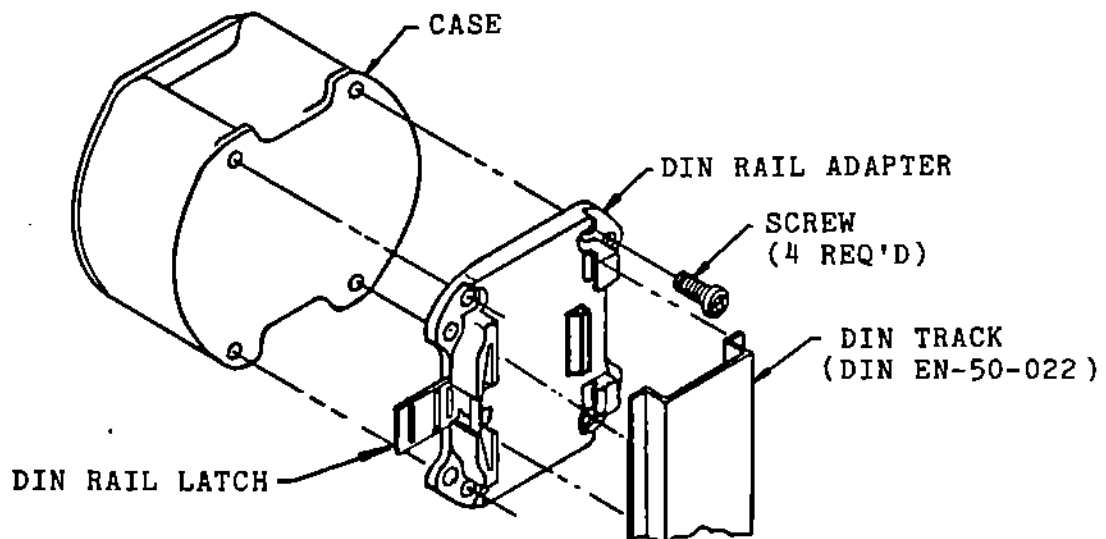

Figure 3-3 Bulkhead and Track Mounting

1. Position plate for desired application.
2. Use #6 hardware to mount plate to back of 502A case.



DIN TRACK MOUNTING: SHOWN FOR HORIZONTAL TRACK



DIN TRACK MOUNTING: SHOWN FOR VERTICAL TRACK

Figure 3-4 DIN Track Mounting

1. Position adapter for desired track direction.
2. Use #6 screws to mount adapter to the back of the 502A case.
3. Snap 502A case assembly onto a DIN rail.

1/2" N.P.T.  
BOTH ENDS

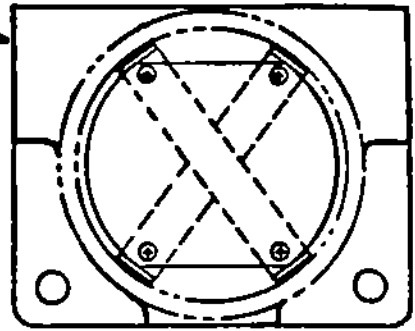

TOP VIEW OF EXPLOSION-PROOF HOUSING.  
UNIT AND HOUSING SHOWN FOR REFERENCE ONLY.

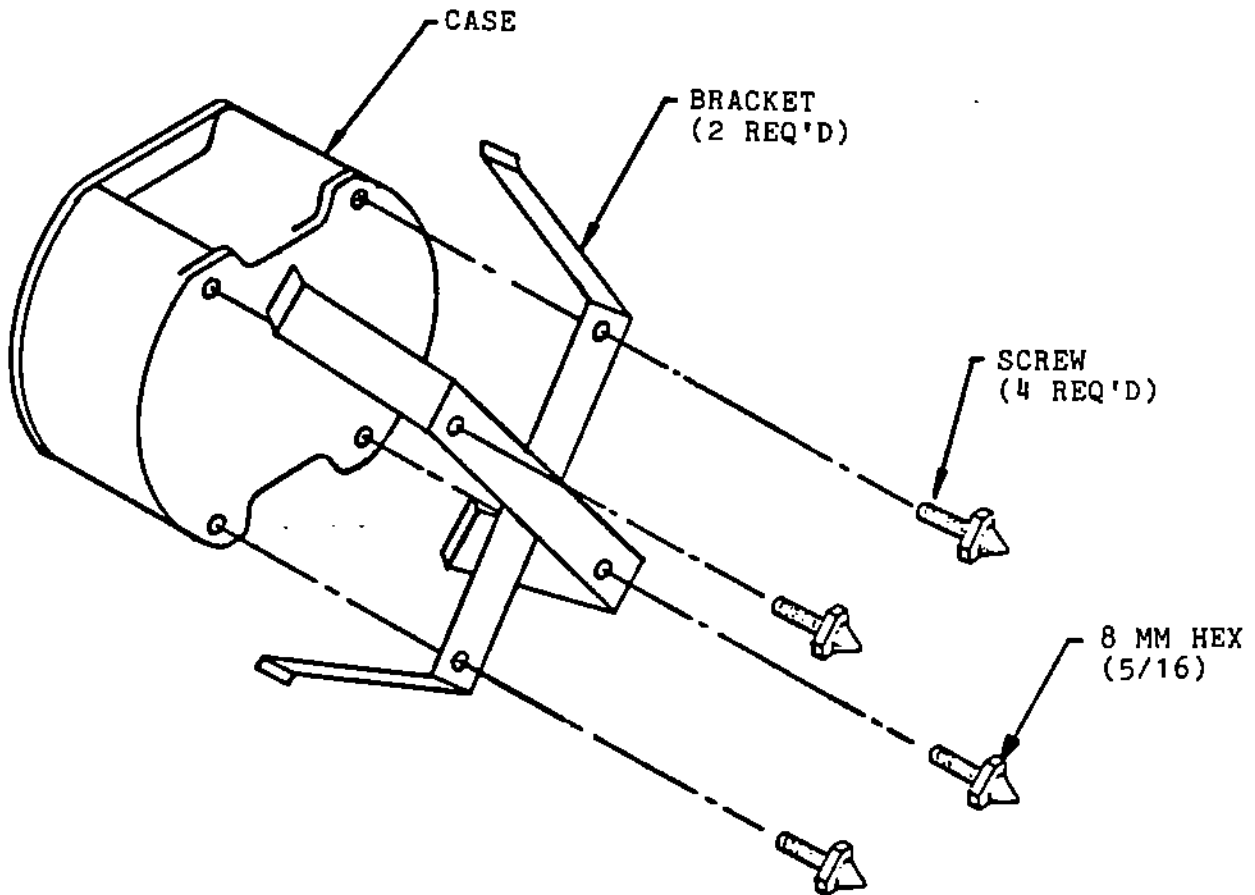

Figure 3-5 Spring Retainer for Explosion-Proof Housing

1. Position the spring retainer across the back of the 502A case.
2. Use wire protector feet (four provided with above option) to hold spring retainers in place.
3. Press the 502A case assembly into an explosion-proof housing.

#### 4.0 POWER AND SIGNAL INPUT CONNECTIONS

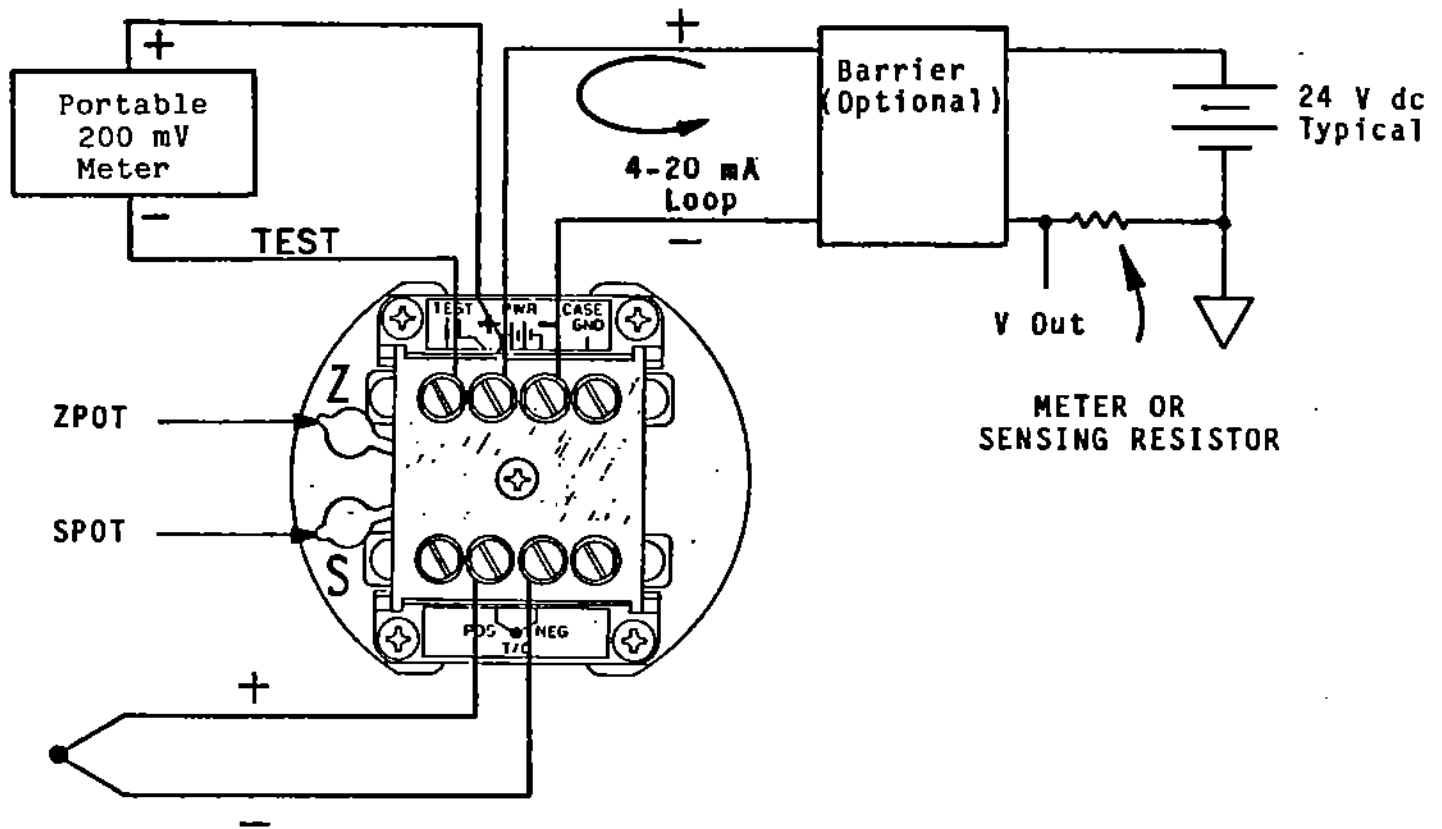

Figure 4-1 Power Input Connections

#### 4.1 GENERAL

TEST, PWR +, and PWR - screws accept 2 mm (13 gauge) or lighter wire. CASE GND is grounded to the case. Power input range is 9-50 V dc.

#### SCREW-TERMINAL PIN ASSIGNMENT

- |   |                      |
|---|----------------------|
| 1 | Test                 |
| 2 | + Power Output       |
| 3 | - Power Output       |
| 4 | Case Ground          |
| a | No Connection        |
| b | + Thermocouple Input |
| c | - Thermocouple Input |
| d | No Connection        |

## 5.0 CONFIGURATION

The 502A-T is normally delivered configured for 4/20 mA = 0-400°C .

## 5.1 TOOLS AND EQUIPMENT

#1 Phillips screwdriver  
3/32" flat blade screwdriver, VACO 17764 or equivalent  
4 1/2 digit DVM (digital voltmeter)  
10 or 100 ohms 1% resistor  
Fixed or variable DC power supply or battery (range of 11-30 V dc)  
-3000 to 55000  $\mu$ V source  
Precision thermometer

KAYE 140 or equivalent 0°C ice-point cell (Optional)

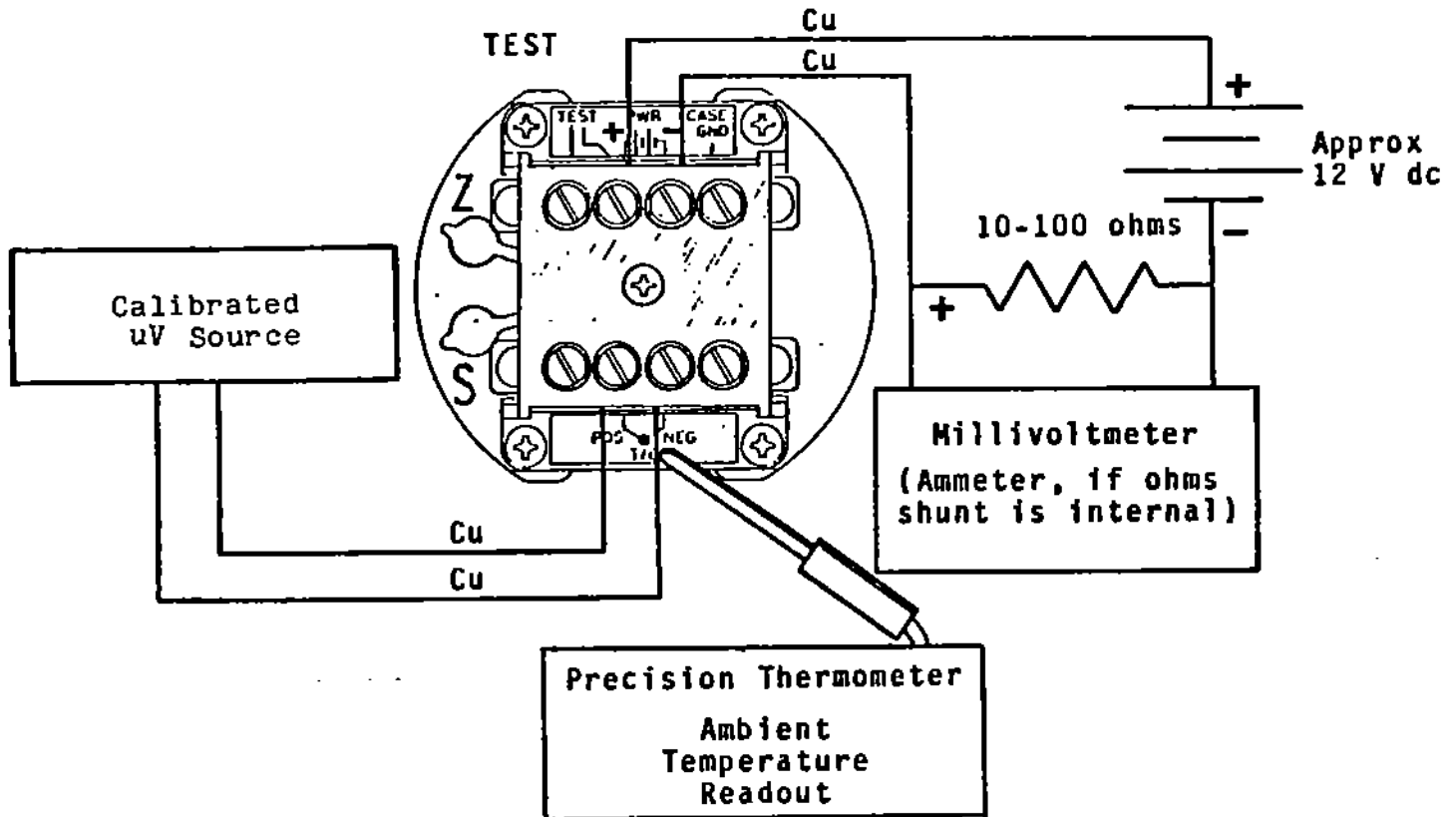

Figure 5-1 Calibration Setup Using Ambient Temperature

## 5.2 CALIBRATION PROCEDURE, AMBIENT TEMPERATURE

1. Remove the outer four screws from the case top and lift out the electronics assembly (attached to the case lid).
2. Pull out the two sealing plugs which cover the Span and Zero potentiometers (S pot and Z pot). Adjust the S pot five turns clockwise (CW) from the fully counter-clockwise (CCW) position.

NOTE: S pot and Z pot are both multi-turn pots; 25 complete turns in a CCW direction will ensure that the pot is fully CCW.

3. Using Table 5-2, select the range which comes closest to your desired 4 and 20 mA temperatures. Note which Zero and Span jumpers are called out in the table for the range selected.
4. Turn the unit so that the jumper pin-forest is in view, and install the push-on jumpers on the positions indicated (see Figure 5-3). Place the unused jumpers in storage positions.

5. Refer to Figure 5-1 and connect the transmitter to the power supply, microvolt source, current shunt, and milliammeter. Place the temperature probe as close as possible to the 502A-T input terminals. Better calibration stability is obtained if the electronic assembly is configured while in the case.
6. Using Table 5-1, determine the microvolt level that the ambient (Room) temperature represents. Subtract this from the microvolt level corresponding to the desired 4.00 mA temperature, found in Table 5-1. This value is LO-IN.
7. Set the microvolt calibration source to LO-IN microvolts and adjust the Z pot until the milliammeter reads 4.00 mA.
8. Using the previously determined microvolt level of the ambient (Room) temperature, subtract this from the microvolt level corresponding to the desired 20.00 mA temperature (Table 5-1). This value is HI-IN.
9. Set the microvolt calibration source to HI-IN microvolts and read the output current on the milliammeter. This current level is designated Initial Top Current (ITC), normally not equal to 20.00 mA.
10. Calculate the Corrected Top Current (CTC) with the following equation (generally this will not equal 20.00 mA).
 
$$CTC = 16 \cdot ITC / (ITC - 4 \text{ mA})$$
11. Adjust the S pot to obtain the Corrected Top Current on the milliammeter.
12. Now readjust the Z pot so that the milliammeter reads 20.00 mA.
13. Set the microvolt source to LO-IN microvolts. If the output current is not 4.00 mA, repeat steps 7 through 12.
14. When calibration is complete, remove the transmitter from the setup and replace the sealing plugs. Reinstall the unit in the case and ensure that the four screws are tightened enough to compress but not flatten the gasket.

EXAMPLE:

Temperature Range = -58 to 662°F or -50 to 350°C \*

\* Conversion Formula for Fahrenheit to Celsius:  $(^{\circ}\text{F} - 32) \times 5/9 = ^{\circ}\text{C}$

Zero Jumper required, None (Table 5-2)

Span Jumper required, None (Table 5-2)

4.00 mA Output = -50°C or -1818.74  $\mu\text{V}$  (Table 5-1)

20.00 mA Output = 350°C or 17816.40  $\mu\text{V}$  (Table 5-1)

Ambient Temperature = 25°C or 991.7  $\mu\text{V}$  (Table 5-1)

*For specific values not given in Table 5-1, interpolation may be used.*

LO-IN = -1818.74 - 991.7 = -2810.44  $\mu\text{V}$

HI-IN = 17816.40 - 991.7 = 16824.70  $\mu\text{V}$

Calibration steps:

1. Adjust the S pot five turns CW from a fully CCW position.
2. Set microvolt source to -2810.44  $\mu\text{V}$ .
3. Adjust the Z pot so that the milliammeter reads 4.00 mA.
4. Set microvolt source to 16824.7  $\mu\text{V}$ .
5. Read the Initial Top Current.
6. Calculate the Corrected Top Current.
7. Adjust the S pot to obtain the Corrected Top Current.
8. Adjust the Z pot to obtain a 20.00 mA current reading.
9. Set microvolt source to -2810.44  $\mu\text{V}$ .
10. If the output is not 4.00 mA, repeat steps 2 through 9.

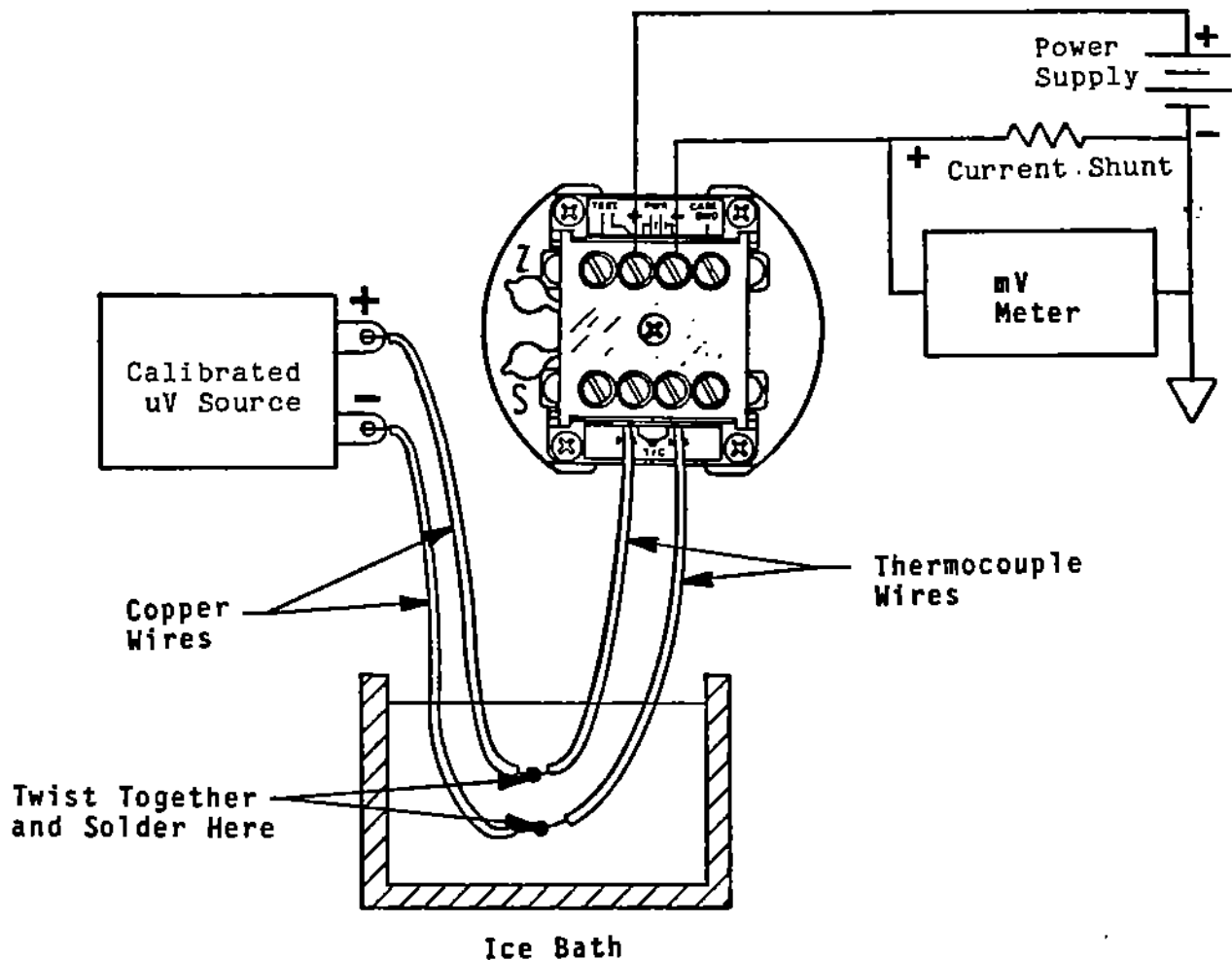

Figure 5-2 Calibration Setup Using Ice-Point Cell

### 5.3 CALIBRATION PROCEDURE, ICE-POINT CELL

1. Remove the outer four screws from the case top and lift out the electronics assembly (attached to the case lid).
2. Pull out the two sealing plugs which cover the Span and Zero potentiometers (S pot and Z pot). Adjust the S pot five turns clockwise (CW) from the fully counter-clockwise (CCW) position.

NOTE: S pot and Z pot are both multi-turn pots; 25 turns in a CCW direction will ensure that the pot is fully CCW.

3. Using Table 5-2, select the range which comes closest to your desired 4.00 and 20.00 mA temperatures. Note which Zero and Span jumpers are called out in the table for the range selected.
4. Turn the unit so that the jumper pin-forest is in view and install the push-on jumpers on the positions indicated (see Figure 5-3). Place the unused jumpers in storage positions.

5. Refer to Figure 5-2 and connect the transmitter to the power supply, microvolt source, current shunt, and millivoltmeter. Ensure that the copper wires from the microvolt source and the thermocouple wires from the 502A-T are soldered together and immersed in the ice bath. Better calibration stability is obtained if the electronic assembly is configured while in the case.
6. Using Table 5-1, determine the microvolt level corresponding to the desired 4 mA temperature. This value is LO-IN.
7. Set the microvolt calibration source to LO-IN microvolts and adjust the Z pot until the milliammeter reads 4.00 mA.
8. Determine the microvolt level corresponding to the desired 20.00 mA temperature. This value is HI-IN.
9. Set the microvolt calibration source to HI-IN microvolts and read the output current on the milliammeter. This current level is designated Initial Top Current (ITC), normally not equal to 20.00 mA.
10. Calculate the Corrected Top Current (CTC) with the following equation (generally this will not equal 20.00 mA).
$$CTC = 16 \cdot ITC / (ITC - 4 \text{ mA})$$
11. Adjust the S pot to obtain the Corrected Top Current on the milliammeter.
12. Now readjust the Z pot so that the milliammeter reads 20.00 mA.
13. Set the microvolt source to LO-IN microvolts. If the output current is not 4.00 mA, repeat steps 7 through 12.
14. When calibration is complete, remove the transmitter from the setup and replace the sealing plugs. Reinstall the unit in the case and ensure that the four screws are tightened enough to compress but not flatten the gasket.

Type T Thermocouple Output Voltage, E, and Slope Sensitivity or Seebeck Coefficient, S, per NBS Monograph 125 (Based on IPTS-68) or IEC publication 584-1, dated 1977.

T °C	E μV	S μV/°C	T °C	E μV	S μV/°C
-50	-1818.74	33.889	50	2035.20	42.808
-40	-1474.73	34.907	60	2467.50	43.649
-30	-1120.67	35.903	70	2908.10	44.470
-20	-756.70	36.889	80	3356.80	45.264
-10	-382.98	37.846	90	3813.30	46.032
0	0.00	38.741	100	4277.30	46.773
10	390.90	39.458	110	4748.70	47.488
11	430.40	39.535	120	5227.00	48.181
12	470.00	39.613	130	5712.20	48.854
13	509.60	39.691	140	6204.10	49.509
14	549.40	39.770	150	6702.40	50.149
15	589.20	39.849	160	7207.00	50.774
16	629.10	39.929	170	7717.80	51.386
17	669.00	40.010	180	8234.70	51.985
18	709.10	40.091	190	8757.50	52.572
19	749.20	40.173	200	9286.10	53.146
20	789.40	40.255	210	9820.30	53.707
21	829.70	40.338	220	10360.20	54.253
22	870.10	40.420	230	10905.40	54.784
23	910.60	40.504	240	11455.80	55.300
24	951.10	40.587	250	12011.30	55.800
25	991.70	40.671	260	12571.70	56.285
26	1032.50	40.756	270	13136.90	56.754
27	1073.30	40.840	280	13706.80	57.210
28	1114.10	40.925	290	14281.10	57.653
29	1155.10	41.010	300	14859.80	58.086
30	1196.20	41.095	310	15442.80	58.511
31	1237.30	41.180	320	16030.00	58.929
32	1278.50	41.266	330	16621.40	59.343
33	1319.80	41.351	340	17216.80	59.751
34	1361.20	41.437	350	17816.40	60.153
35	1402.70	41.523	360	18419.90	60.545
36	1444.30	41.608	370	19027.20	60.919
37	1485.90	41.694	380	19638.20	61.265
38	1527.70	41.780	390	20252.30	61.564
39	1569.50	41.866	400	20869.20	61.793
40	1611.40	41.952			

Table 5-1 Type T Thermocouple Reference Table

NOTE: Table above provides one degree steps from 10 to 40°C to facilitate ambient-temperature calibration method.

JUMPERS USED		POTENTIOMETER SETTINGS							
SPAN	ZERO	ZPOT=CW SPOT=.7CW		ZPOT=CCW SPOT=.7CW		ZPOT=CCW SPOT=CCW		ZPOT=CW SPOT=CCW	
		Output		Output		Output		Output	
		4 mA	20 mA	4 mA	20 mA	4 mA	20 mA	4 mA	20 mA
NONE	NONE					-50	400	0	400
	D			-50	230				
	C			-40	265				
	C,D	-50	235	10	295				
	B	-35	265	55	330				
	B,D	15	300	100	360				
	B,C	60	335	140	390				
	B,C,D	105	365	180	400				
	A	145	400						
E	NONE			-50	140	-50	285	0	340
	D			-20	140	-45	315	45	370
	C	-50	110	25	175	0	345	85	400
	C,D	-20	145	70	210	45	375		
	B	30	180	110	245	90	400		
	B,D	75	215	150	280				
	B,C	115	250	185	315				
	B,C,D	155	285	225	350				
	A	195	320	260	380				
	A,D	230	355	295	400				
	A,C	270	390						
	A,C,D	305	400						
	F	NONE			-40	60	-50	150	0
D		-50	20	5	100	-50	185	40	250
C		-40	65	50	135	0	220	80	280
C,D		10	105	90	175	45	250	120	310
B		55	140	130	210	85	285	160	345
B,D		95	180	170	245	125	315	195	375
B,C		135	215	205	280	165	350	235	400
B,C,D		175	250	245	315	205	380		
A		215	285	280	350	240	400		
A,D		250	320	315	385				
A,C		285	355	350	400				
A,C,D		325	390						
A,B		360	400						
G	NONE			-25	35	-50	65	-5	135
	D	-50	-5	20	75	-50	100	40	170
	C	-25	35	65	115	0	140	80	205
	C,D	25	80	105	150	45	175	120	240
	B	65	120	140	190	85	210	160	270
	B,D	110	155	180	225	125	245	195	305
	B,C	145	195	215	260	165	275	230	340
	B,C,D	185	230	255	295	200	310	270	370
	A	225	265	290	330	240	345	305	400
	A,D	260	300	325	365	275	380		
	A,C	295	340	360	400	310	400		
	A,C,D	335	375						
	A,B	370	400						

Table 5-2 Celsius Temperature Ranges Obtained With Jumpers

Figure 5-3 Jumper Diagram

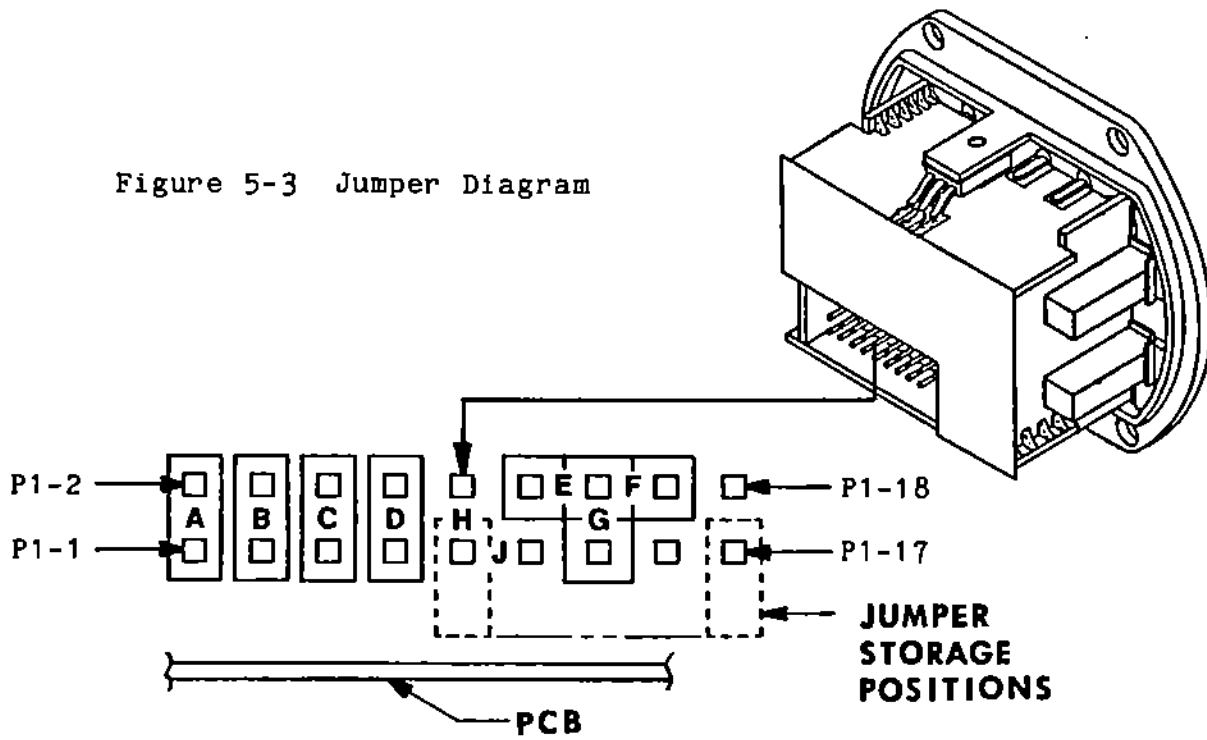

5.4 PIN ASSIGNMENTS (Jumper Pin-forest P1)

Jumper Function	P1 Pins Used
'A' Zero	1 and 2
'B' Zero	3 and 4
'C' Zero	5 and 6
'D' Zero	7 and 8
'E' Span	12 and 14
'F' Span	14 and 16
'G' Span	13 and 14

NOTE: P1 connector pins 9, 10, 11, 15, 17 and 18 are used solely for computerized testing by the factory.

5.5 CALIBRATION FORMULA (Alternate to Using 4 mA to 20 mA Tables)

5.5.1 Calculation of ZEXTRA

When the SPAN pot is turned Clockwise it increases the output, decreasing the SPAN required for full-scale output and adding ZEXTRA, which is used to set the Zero (4 mA Temperature) jumpers.

$$ZEXTRA = (MAXSPAN - SPAN) / 4$$

5.5.2 Zero Jumper Selection (Equation alternate to Table 5-2)

From none to four jumpers may be placed on the connector to suppress the ZERO (temperature corresponding to 4 mA output). The equation is:

$$(ZERO+ZEXTRA) = 90 (8A+4B+2C+D) + 70 \times ZPOT, \text{ } ^\circ\text{C}$$

Where we put in a '1' for each jumper used (A,B,C,D) and the value of ZPOT ranges from +1.0 to 0 to -1.0 as we turn it Clockwise.

NOTE: Store the unused jumpers between the bottom connector pins and the printed-circuit board.

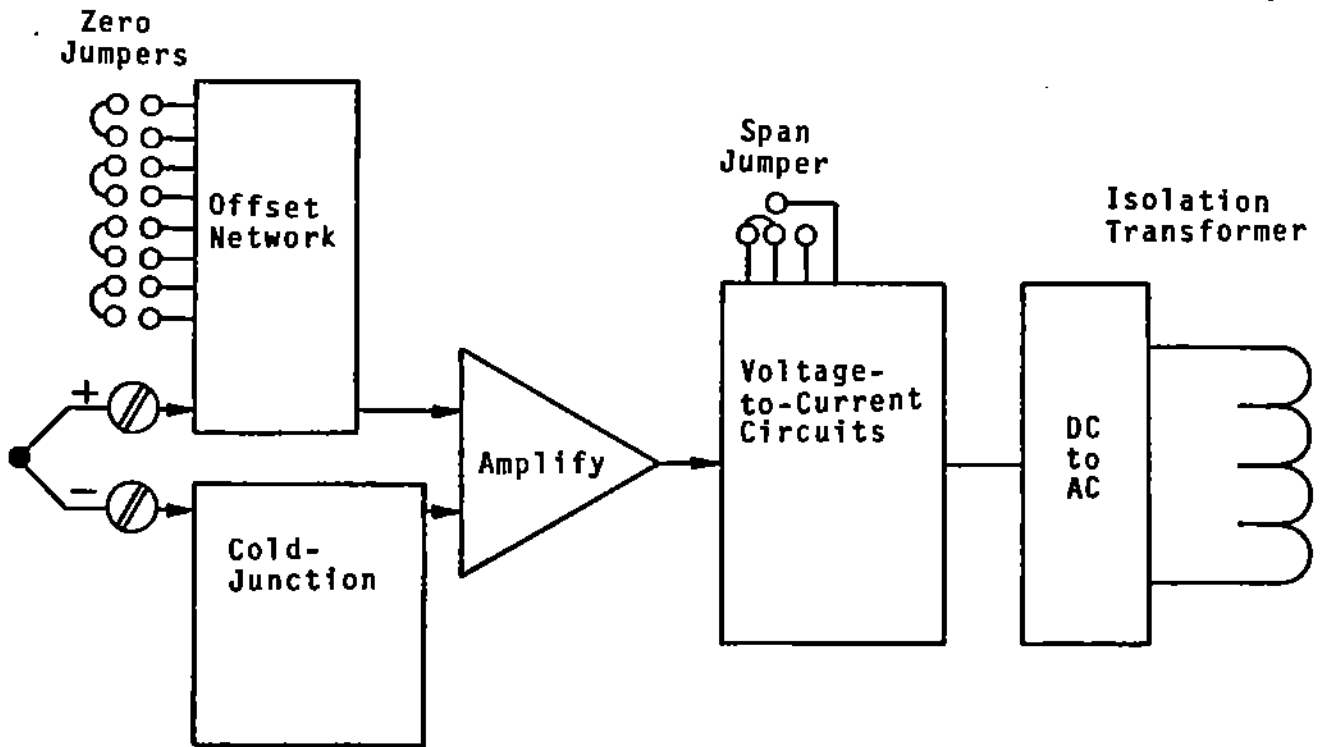

Figure 6-1 502A Preamp Block Diagram

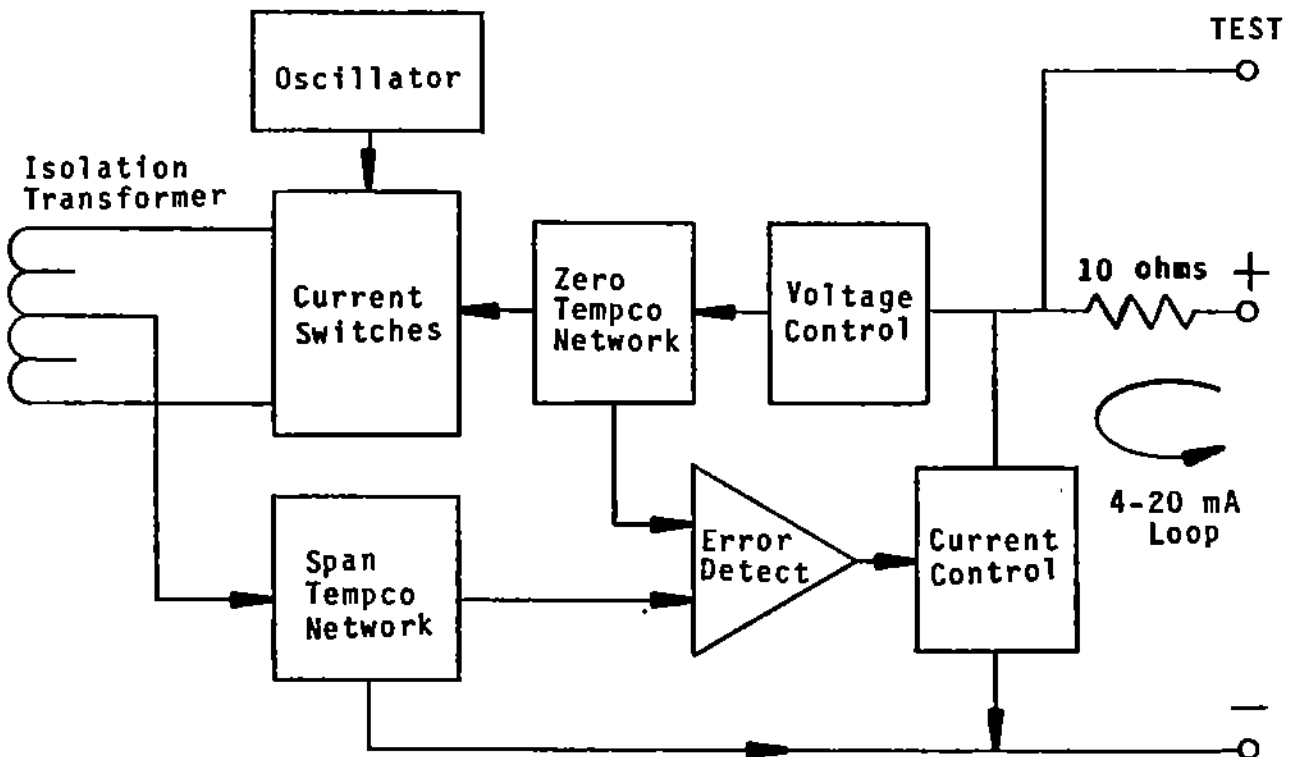

Figure 6-2 502A Postamp Block Diagram

## TRANSMITTER ACCURACY SPECIFICATIONS

The complex current-transmitter circuitry necessary to amplify, isolate, protect, and offset weak input signals while consuming only small amounts of power can distort the signal in many ways. Additional accuracy limitations occur in thermocouple transmitters, which require precise cold-junction compensation and large Zero-suppression ranges in order to obtain good sensitivity and linearity for high temperatures.

Many transmitter data sheets omit key accuracy factors and/or express performance in percentage values without mentioning the full-scale value. Design limitations can be disguised by such "specsmanship"; the 502A specifications, however, are detailed in order to present the complete performance accuracy.

For a given thermocouple type, input errors are logically expressed in degrees (rather than microvolts), and output errors are readily expressed in microamperes, since output is current. Transmitter users are rarely interested in microamperes. Therefore, these output current errors are translated back to input degrees as a percentage (or ppm) of the selected Span.

Another fundamental division of errors is that of independence or dependence on Zero and Reading. Resistor aging and tempco mismatch in the Zero and Voltage Reference circuits, for example, will produce errors which increase with Zero suppression but which are independent of the amount of Reading (value above the Zero). Resistor aging and tempco mismatch in the amplifier gain (feedback) circuits, however, will usually affect both Zero and Reading accuracy, while amplifier gain tempco variations are important to just the Reading stability. A complete error specification, therefore, needs a term proportional to Zero (suppression) and a term proportional to Reading.

For thermocouple transmitters, the Cold-Junction Compensation (CJC) is never perfect, even when factory-tailored over wide ambient excursions with curvilinear adjustments, as in the 502A. This error component is readily stated as a percentage of the ambient temperature excursion from the nominal temperature at which the Zero was set (assuming, as in the 502A, that the Zero potentiometer has ample resolution on all Zero and Span ranges). For transmitters with restricted turndown ratios (low Zero Suppression capability), the tempco errors may be lumped into a single error term.

In addition to these three components of tempco (ambient temperature effects), there are other possible errors, often referred to as "hysteresis," "repeatability," "drift," or "time" errors. No statistically-significant errors of these types have yet been observed for the 502A, which utilizes a solid-state, band-gap input voltage reference, matched-pair input PNP transistors, integrated-circuit current source and imbalance control, and matched-tempco bridge resistors. The 502A also provides a variable-tempco output adjustment (factory-set) which eliminates many of the errors lumped in this category for other units. The 502A specification includes a 0.2°C tolerance for the calibration accuracies.