

821 THERMAL PRINTER

07421

JAP0195NBBA

© COPYRIGHT 1994, NEWPORT ELECTRONICS, INC. All rights reserved.

This documentation may not be copied, photocopied, reproduced, translated, or reduced to any electronic medium or machine-readable form, in whole or in part, without prior written consent of NEWPORT ELECTRONICS, INC.

CHG	ECO NO	DATE	BY	CHK
E	7113	20 MAY 91	MV	

TABLE OF CONTENTS

	Page
1.0 Description.....	1
1.1 General.....	1
1.2 Specifications.....	2
2.0 Receiving and Installation.....	4
2.1 Unpacking and Inspection.....	4
2.2 Initial Checkout.....	4
2.3 Installation.....	5
2.4 Installed Shipment.....	5
3.0 Operating Instructions.....	6
3.1 Introduction.....	6
3.2 Controls and Indicators.....	6
3.3 Pin Assignments.....	9
3.4 ASCII Codes.....	9
3.5 Operating Modes.....	12
3.5.1 Parallel ASCII Mode.....	13
3.5.2 Serial ASCII Mode.....	14
3.5.3 Test Mode.....	17
3.6 DIP Switch Functions.....	18
3.7 Parallel ASCII Setup.....	22
3.8 Serial ASCII Setup.....	23
3.9 Test Setup.....	25
4.0 Theory of Operation.....	27
4.1 Printhead Operation.....	27
4.2 Motor Drive.....	27
4.3 DIP Switches.....	28
4.4 Parallel ASCII Input Circuits.....	28
4.5 Serial ASCII Input Circuits.....	28

5.0	Maintenance and Troubleshooting.....	30
5.1	Front Sub-Panel Access.....	30
5.2	Main Circuit Board Access.....	30
5.3	Paper Installation or Replacement.....	31
5.4	Cleaning the Printhead.....	32
5.5	Printing Mechanism.....	33
5.6	Troubleshooting.....	33
6.0	Drawings.....	35
	Schematic, 821 Printer Processor.....	35
	Assembly, Processor PC Board.....	37
	Schematic, Print and Control.....	38
	Assembly, Print and Control.....	39
	Schematic, Power Supply.....	41
	Assembly, Thermal Printer.....	42
	Assembly, Power Supply.....	43
	Outline and Mounting.....	44
Appendix A	Definition of Terms.....	45
Appendix B	Interfacing Serial ASCII (RS-232-C).....	49
B.1	General.....	49
B.2	The RS-232-C Signal.....	49
B.3	EIA Standard Pin Assignments.....	51
B.4	Printer Interface.....	53
B.5	Rear Connector.....	54
B.6	Interface Procedure.....	54
B.7	Missing Characters.....	56
B.8	TRS-80 Application Program.....	59
Appendix C	Serial Interface Adapter.....	60
C.1	General.....	60
C.2	Procedure.....	61

1.0 DESCRIPTION

1.1 GENERAL

Newport's Model 821 text and data printer is a compact microcomputer-controlled thermal printer for use with computers, data terminals, and instruments. It is capable of printing 20 columns of alphanumeric characters at speeds up to 1.5 lines per second. The 96 ASCII characters are formed in a 5 x 7 dot matrix that extends to 5 x 9 for lower case letters with descenders. In addition, six special character symbols are provided; omega, micro, degrees, overload, high alarm and low alarm.

If desired, switch selection allows the non-printable control characters to be printed in reverse (white on a black background) for easy identification. A two-line 41-character buffer allows characters to be received in bursts at a rate higher than the allowable average. There are two switch-selectable printing directions that provide either normal data listing (the new line is printed above the previous line) or inverted text printing (the new line is printed below the previous line).

A self-test mode prints five different patterns for verifying proper operation of the printhead and drive circuitry. An out-of-paper condition lights a red indicator on the front panel and prevents further printing until paper is reloaded. Printing is not resumed until the front panel PRINT pushbutton is activated, thus preventing loss of data.

The Model 821 interfaces to either parallel ASCII or serial ASCII data sources. Parallel data is TTL Centronics-compatible and serial data is either RS-232-C, 20 mA current-loop, or TTL-compatible. In the parallel mode, 7-bit data can be accepted in 3600 characters/sec. bursts. In the serial mode, 6-, 7- or 8-bit data can be accepted at switch-selectable rates of 110 to 2400 baud with odd, even or no parity.

A sturdy extruded aluminum DIN case measuring approximately 3-1/2 inches on a side and 9 inches long, houses the printer and the paper roll. It is suitable for bench-top or panel-mount operation.

The Model 821 Printer is intended for instrumentation or data processing systems where alphanumeric data must be printed. The printer is completely self-contained and may be directly attached to a serial data source (e.g. TTL, RS-232-C, or 20 mA current loop) or to the parallel port of a microcomputer, CRT terminal or electronic instrument.

1.2 SPECIFICATIONS

1.2.1 Printout

Number of Columns	20
Characters Printed	Full 96-character ASCII set plus 6 special characters: mu, omega, degrees, overload and high/low alarms.
Character Format	5 x 9 dot matrix
Character Spacing	3.5 characters/cm (9/in)
Character Size (W x H)	2.03 mm x 3.00 mm (0.08 in x 0.12 in)
Line Spacing	2.3 lines/cm (5.7/in)
Print Rate	1.6 lines per second @ 60 Hz 1.3 lines per second @ 50 Hz
Print Intensity	Potentiometer adjustable through rear panel.

1.2.2 Paper

Type	Newport and 3M paper, black characters
Alternate Type	T1 thermal paper, blue characters
Roll Dimensions	
Width	57.3 mm (2.257in)
Diameter	66.7 mm (2.625in)
Length	56 meters (184ft)
Lines/Roll	12,500 lines
Time/Roll	2.1 hours minimum

1.2.3 Print Mechanism

Printhead	20-column array of solid-state single-crystal silicon mesas.
Paper Motion	Stepper motor with gear reduction and friction roller. A line may be viewed immediately after printing.
Paper Out	Printing stops and a paper-out indicator lights.

1.2.4 Controls

Front Panel	POWER-ON Indicator, PRINT Pushbutton FEED (Paper Advance) Pushbutton PAPER-OUT Indicator
Front Sub-Panel (DIP switch selection)	Baud Rate, Parity, Auto L/F, Run/Test
Main Circuit Board Control Options (DIP switch selection)	Signal Polarities, Serial/Parallel, Data/Text, Word length

2.0 RECEIVING AND INSTALLATION

2.1 UNPACKING AND INSPECTION

Your Model 821 Thermal Data Printer was carefully inspected and tested before shipment. Unpack the printer and perform a visual inspection to assure that no damage has occurred during shipment or handling. Because extensive damage could result from attempts to measure circuit parameters or to troubleshoot the printer by non-factory personnel, the warranty is void if the unit shows signs of unauthorized repair.

NOTE

No attempt should be made to operate this printer without reading Section 3 of this manual. External connections and internal switch positions are required to make it operate in the desired manner.

2.2 INITIAL CHECKOUT

After unpacking the printer and paper roll, follow these steps to verify that the printer is operating properly.

- (1) Connect the line cord to the unit and apply the ac line voltage specified on the label (either 115 V or 230 V). Since there is no power switch, the green LED "Power-on" indicator above the PRINT pushbutton should light and since there is no paper installed, the red LED "Out-of-paper" indicator above the FEED pushbutton should light.
- (2) Install the roll of paper according to the instructions in Section 5.3 (Maintenance). The red LED "Out-of-paper" indicator should extinguish.
- (3) While the plastic front panel trim bezel is removed, locate the 8-pole DIP switch (S1) next to the PRINT pushbutton and set all 8 poles to their ON position.
- (4) Press the front panel RESET button and then the PRINT button. This initiates a self-test printout of all characters in a ripple pattern. Each line begins with the second character of the previous line. To stop the printing, push the PRINT button once again and hold until printing stops. It acts as an alternate action ON/OFF print control during self-test.
- (5) If the paper doesn't advance or the printer gives off a popping sound while printing relatively dark, turn the DOT INTENSITY adjustment on the rear panel for lighter printing.

*** CAUTION ***

The Printer has been shipped with the intensity control in the proper position and should not need adjusting. Check for proper paper installation before altering the factory setting.

- (6) If the paper sticks occasionally to produce uneven line spacing, clean the printhead according to the instructions in Section 5.4 (Maintenance).

2.3 INSTALLATION

See Section 6 for printer outline and panel mounting drawings. Because of the weight, a 0.1 inch steel or 0.125 inch aluminum panel is recommended.

When mounted in thinner panels, the printer should be rear supported. Brackets can be attached over the rear 10-32 studs and under the wing nuts used for the slide retainers. Alternately, the bracket can be attached under the 6-32 screws which hold the rear plate.

The unit is inserted from the front of the panel with the slide retainers removed. The slide retainers are then installed from the rear and held in place with a U-bracket and wing nuts. Use only finger strength for tightening the wing nuts.

2.4 INSTALLED SHIPMENT

Because of the cantilever effect when panel-mounted, the printer should have rear bracing as described above for shipment as a subassembly in other equipment. The paper roll should also be removed.

3.0 OPERATING INSTRUCTIONS

3.1 INTRODUCTION

This section contains information necessary for proper operation of the Model 821 Thermal Printer. Identification of controls and switches, pin assignments for the connectors, I/O signal description, set-up and general operating information are included in this section.

The Model 821 interfaces with two types of input data, parallel ASCII and serial ASCII, but not simultaneously. The signals for the parallel ASCII data are interfaced via a 16 pin PCB connector and for the serial ASCII data via a 25 pin D type connector. Since the printer can operate in only one mode (parallel or serial) at a time, only the connector corresponding to the selected mode need be inserted. In fact, due to rear panel space limitations, there is insufficient clearance for both connectors to be inserted simultaneously.

3.2 CONTROLS AND INDICATORS

3.2.1 Front Panel Controls

These two controls are accessible from the front of the printer with the bezel in place.

PRINT Momentary pushbutton that manually initiates a print cycle.

FEED Momentary pushbutton that continuously advances the paper as long as it is held depressed.

3.2.2 Front Panel Indicators

These two indicators are visible from the front of the printer with the bezel in place.

POWER ON A green LED lamp above the PRINT pushbutton indicating that ac power is applied to the printer.

PAPER OUT A red LED lamp above the FEED pushbutton indicating that the paper has run out.

3.2.3 Front Sub-Panel Controls

These controls (Figure 3.1) are accessible when the front bezel is removed by squeezing in at the middle of the two sides and pulling.

RESET Momentary pushbutton switch that causes the internal microcomputer to reset and read the current position of all of the programming DIP switches. It must be pushed after changing the DIP switches to enter the new settings. As an alternative, the microcomputer can also be reset by turning the power off and on.

DIP SWITCH S1 An 8-pole DIP switch that sets the baud rate, and type of parity for serial ASCII and selects the Run/Test mode.

3.2.4 Main Board Controls

These controls are accessible at the edge of the main board when the printer is removed from the case (Figure 3.2).

DIP SWITCH S5 An 8-pole DIP switch that inverts the logic polarity of the interface signals, sets the word length for serial ASCII, selects the Serial/Parallel mode, Data/Text mode and Negative/Positive Data.

DIP SWITCH S6 A 4-pole DIP switch that selects serial TTL, special characters to be printed and BUSY logic polarity.

3.2.5 Rear Panel Control

This control is accessible through a hole in the rear of the case (Figure 3.3).

INTENSITY ADJUST This rear panel screwdriver adjustment varies the intensity of the printed data. Clockwise rotation darkens the printout. This intensity is temperature and paper-type sensitive. Let the printer reach its quiescent printing temperature before attempting adjustment. If the intensity is adjusted too dark, some papers will stick and fail to advance.

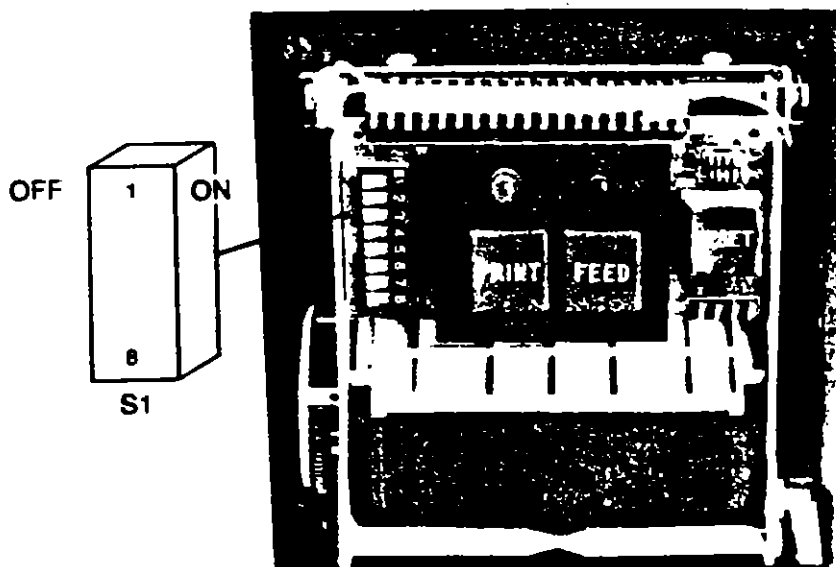

Figure 3.1 Sub-Panel Controls

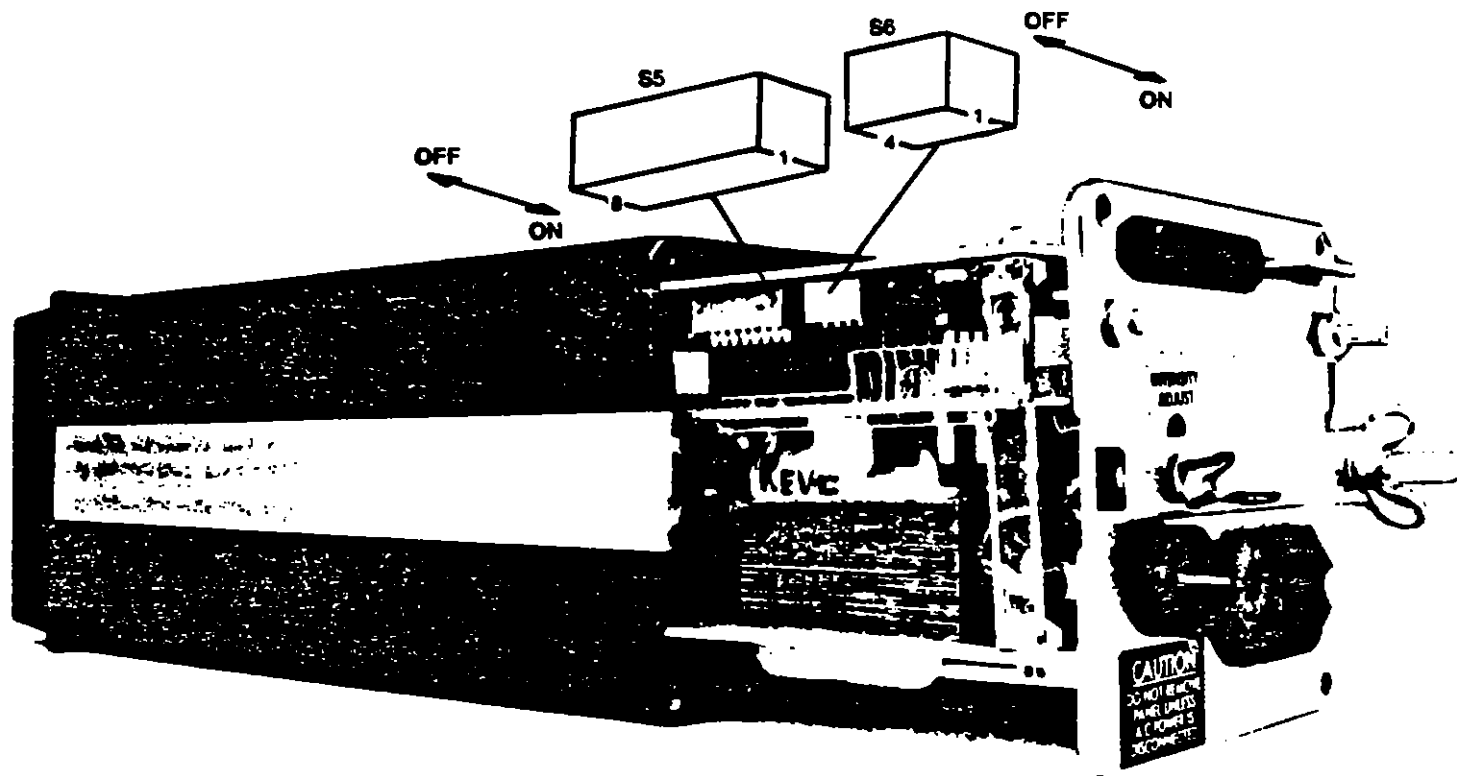

Figure 3.2 Main Board Controls

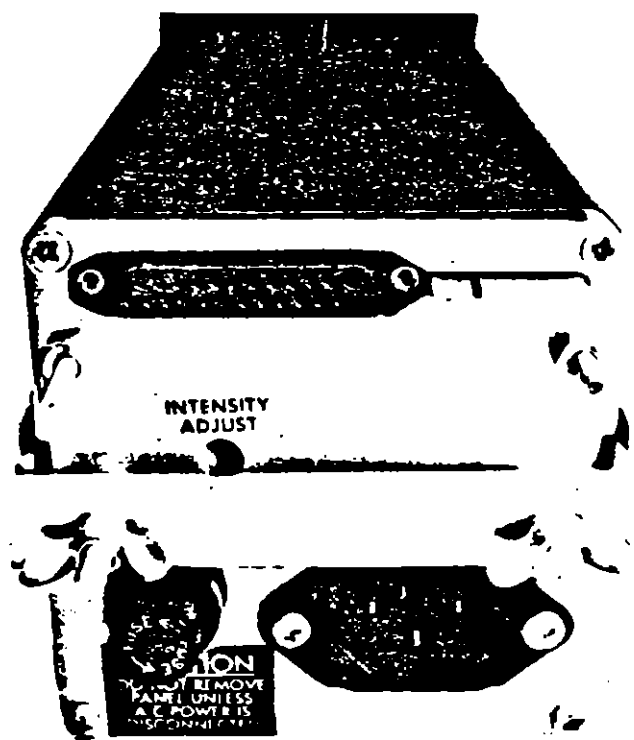
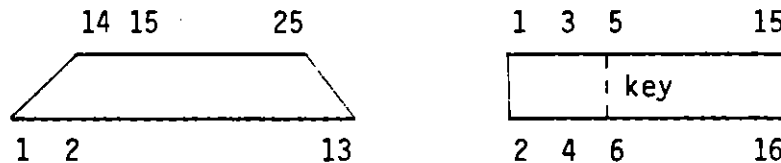

Figure 3.3 Rear Panel Controls

3.3 PIN ASSIGNMENTS

The following are the pin assignments for the parallel ASCII connector and the serial ASCII connector. There are three serial ASCII interfaces; RS-232-C, 20 mA current loop and TTL. All use the same 25 pin subminiature D connector, but different sets of pins. The serial data format for all three is the same, only the voltage and impedance levels are different.

P1	P9
Serial ASCII Connector 25-pin DB25S Subminiature	Parallel ASCII Connector 16-pin PCB Fingers
RS-232-C	
1 CHASSIS GROUND	1 PAPER OUT
3 RECEIVE DATA	2 PRINTER SELECT
4 REQUEST TO SEND (RTS)	3 STROBE
6 DATA SET READY (DSR)	4 +5 VOLTS OUT
7 SIGNAL GROUND	5 GROUND
10 -TEST	6 BUFFER FULL
20 DATA TERMINAL READY (DTR)	7 ACKNOWLEDGE
	8 BUSY
20 mA Current Loop	9 DATA BIT 7
11 BUFFER FULL (TTL)	10 DATA BIT 6
12 DATA INPUT	11 DATA BIT 5
24 DATA RETURN	12 DATA BIT 4
	13 DATA BIT 3
TTL Levels	14 DATA BIT 2
7 SIGNAL GROUND	15 DATA BIT 1
11 BUFFER FULL	16 DATA BIT 0
12 DATA INPUT	
24 DATA RETURN	
(connect Pin 24 to Pin 7)	



Rear View of Printer Connectors

Figure 3.4

3.4 ASCII CODES

Table 3.1 lists the 96 printable characters and 32 control functions corresponding to the 128 ASCII codes that can be received by the printer. All of the standard 96 characters shown in columns 2 through 7 are printed, including the lower case alphabet. However, most of the control functions are ignored, except that six of those ignored, may, as a setup option, cause the printing of special characters. Section 3.4.1 lists the special characters and their corresponding codes while Section 3.4.2 lists the control codes that are recognized by the printer. The ignored control characters may be printed for identification as described in Section 3.4.3.

				DB6 DB5 DB4		0 0 0	0 0 1	0 1 0	0 1 1	1 0 0	1 0 1	1 1 0	1 1 1
D B 3	D B 2	D B 1	D B 0	COLUMN		0	1	2	3	4	5	6	7
				ROW DEC	HEX								
0	0	0	0	0	0	NUL	DLE	SP	0	@	P	~	p
0	0	0	1	1	1	SOH	DC1	!	1	A	Q	a	q
0	0	1	0	2	2	STX	DC2	"	2	B	R	b	r
0	0	1	1	3	3	ETX	DC3	#	3	C	S	c	s
0	1	0	0	4	4	EOT	DC4	\$	4	D	T	d	t
0	1	0	1	5	5	ENQ	NAK	%	5	E	U	e	u
0	1	1	0	6	6	ACK	SYN	&	6	F	V	f	v
0	1	1	1	7	7	BEL	ETB	'	7	G	W	g	w
1	0	0	0	8	8	BS	CAN	(8	H	X	h	x
1	0	0	1	9	9	HT	EM)	9	I	Y	i	y
1	0	1	0	10	A	LF	SUB	*	:	J	Z	j	z
1	0	1	1	11	B	VT	ESC	+	;	K	[k	{
1	1	0	0	12	C	FF	FS	,	<	L	\	l	
1	1	0	1	13	D	CR	GS	-	=	M]	m	}
1	1	1	0	14	E	SO	RS	.	>	N	^	n	~
1	1	1	1	15	F	SI	US	/	?	O	-	o	DEL

CONTROL
FUNCTIONS

STANDARD

ASCII Codes

Table 3.1

3.4.1 Special Characters

The control codes shown in column 1 and decimal rows 10-15 may be ignored (DIP switch S6-3 OFF) or may cause the printing of the following special characters (S6-3 ON). The decimal code is obtained by multiplying the column number by 16 and adding the row number (DEC).

<u>Symbol</u>	<u>Name</u>	<u>Decimal Code</u>	<u>Hex Code</u>
μ	Mu (Micro)	26	1A
Ω	Omega (ohm)	27	1B
⚠	LO Alarm	28	1C
⚠	HI Alarm	29	1D
⚡	Overload (OL)	30	1E
°	Degrees Sign	31	1F

3.4.2 Control Codes

The printer recognizes the following control codes.

<u>Control Function</u>	<u>Decimal Code</u>	<u>Hex Code</u>	<u>Action</u>
Null (NUL)	0	00	This code is ignored by the printer and may be sent at any time. No action is taken if this character is received.
Backspace (BS) Delete (DEL)	8 127	08 7F	The actions caused by these two codes are identical. If there are no printable characters in the print line, no action is taken; otherwise, the character pointer is moved back (left) one print position and the last printable character received is deleted from the buffer.
Horizontal Tab (HT)	9	09	This is printed as a space.
Line Feed (LF)	10	0A	This code causes the current line in the buffer to be printed, followed by a line feed but no carriage return. The first character of the next line will be printed in the character position following the last character position printed in the current line.

Vertical Tab (VT)	11	0B	This code causes the current line to be printed, then advances one additional line (doublespaces). The first character of the next line will be printed in the character position following the last character printed in the current line.
Carriage Return (CR)	13	0D	This code causes the current line to be printed. The next character received will be printed in position 1 of the next line. Therefore a CR has the effect of a print command followed by a CR followed by a LF.

3.4.3 Invalid Characters

Any control character that is not in the special 6-character set enabled by switch S6-3 nor a recognized control character as defined in 3.4.2 above, is an invalid character. All invalid character codes may be converted to printable character codes by DIP switch selection (S1-7 OFF). They are then printed in reverse-field (white on black) format to alert the user to their presence and to identify their code. The decimal code of the control function has decimal 64 added to it to generate a printable character. Therefore, to determine an unknown control code, first identify the printable character (white on black), find its decimal code and then subtract 64 to obtain the control code.

Invalid characters may be ignored and the printing of their equivalent character codes may be inhibited by setting DIP switch S1-7 ON.

3.5 OPERATING MODES

There are three operating modes for the Model 821 Thermal Printer; parallel ASCII, serial ASCII and self-test. For a definition of parallel ASCII, serial ASCII and other terms, see Appendix A. For a detailed description of the serial ASCII data format, see Appendix B.

The interface signals and their timing is described in Section 3.5.1 for the parallel ASCII mode and in Section 3.5.2 for the serial ASCII mode. The DIP switch positions and functions are described in Section 3.6 as a prelude to the setup instructions in Sections 3.7 for parallel ASCII and 3.8 for serial ASCII.

3.5.1 Parallel ASCII Mode

In this mode the Model 821 printer accepts parallel 7-bit ASCII data (see code table in Section 3.4). An 8-bit port is provided but the eighth bit is ignored. A dual row, 8-pin PCB connector P9 provides connections for the data and control signals. The least significant bit is connected to DATA BIT 0 and the most significant bit to DATA BIT 6. DATA BIT 7 is the eighth and unused bit. The 7 bits representing an ASCII character appear simultaneously on these input data lines. When these lines have settled, the sending device produces a pulse that is applied to the STROBE input of the printer. When the STROBE pulse is received, the printer generates a BUSY Signal to prevent the sending device from changing the data and then latches the data into an input buffer. After the data byte has been accepted, an ACKNOWLEDGE pulse is generated by the printer and BUSY returns to the false condition. The sending device is now free to send the next data byte. This sequence is shown in the timing diagram of Figure 3.5.

The printer contains a two line, 41 byte input buffer to store data that is being received in bursts at a rate faster than the average printing rate. When the current strobed data byte causes a buffer full condition, the BUFFER FULL line goes true and prevents the generation of an ACKNOWLEDGE pulse (BUSY line therefore remains true) until after the buffer full condition has cleared by printing part of the buffer contents.

When the buffer can once again accept data, the BUFFER FULL line returns false, an ACKNOWLEDGE pulse is sent that clears the busy condition and causes BUSY to return false. This indicates to the sending device that the last data byte has been accepted and the printer is ready for more data.

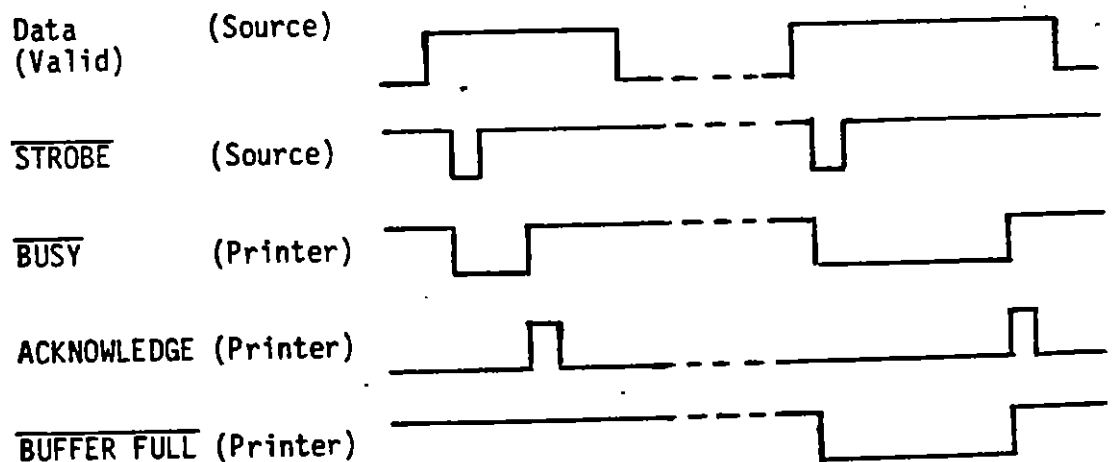

Parallel ASCII Timing Diagram

Figure 3.5

The $\overline{\text{STROBE}}$ pulse width must be from 3 usec to 180 usec. The $\overline{\text{BUSY}}$ line will remain true 200 usec to 450 usec if the buffer is not full. The maximum input burst rate is 3600 characters/second while the maximum average print rate is about 30 characters/second.

A minimum 2-wire handshake can be implemented by using certain combinations of the control signals.

(1) $\overline{\text{STROBE}}$ and $\overline{\text{BUSY}}$

While Busy is true, the input data must not change.

(2) $\overline{\text{STROBE}}$ and ACKNOWLEDGE

Following the STROBE pulse, data must not change until the ACKNOWLEDGE pulse is received.

(3) $\overline{\text{STROBE}}$ and $\overline{\text{BUFFER FULL}}$

Following the $\overline{\text{STROBE}}$ pulse, data must not change for 500 usec and then only if $\overline{\text{BUFFER FULL}}$ is false.

These control signals are individually programmable by DIP switches for either positive-true or negative-true logic polarities. The timing diagram of Figure 3.5 shows the logic polarities for the switches in the OFF position.

After reading Section 3.6 (DIP switches), see Section 3.7 for the parallel ASCII setup instructions.

3.5.2 Serial ASCII Mode

In this mode, the Model 821 printer accepts asynchronous bit-serial data in the RS-232-C format. See Appendix B for a complete description of the RS-232-C bit-serial signal. Several types of circuit interfaces are available including RS-232-C, isolated 20 mA current loop, TTL, LSTTL and CMOS.

There is considerable confusion in the literature and among instrument-makers concerning the implementation of the RS-232-C serial interface standard. The Electronics Industries Association (EIA) RS-232-C standard defines only the connector configuration and voltage levels for serial data communications between data-terminal equipment in certain defined system applications. Interfacing problems often arise in the following areas:

- (1) Matching the bit stream characteristics between sender and receiver including baud rate, number of bits/word, parity bit and number of stop bits.
- (2) Matching the wired connections between the sender and receiver including not only the data lines but also the handshake lines.
- (3) Realizing the characteristics and limitations of the sending and receiving buffer registers as they relate to the errorless transfer of data with and without handshaking.

To reduce the interface problems, Appendix B provides a definition of the signals and connections for serial ASCII communications. It lists the restrictions and limitations of the resulting system and suggests an approach for the successful connection of the Model 821 to a sending device.

NOTE

If, after reading this section and Section 3.8 (Serial ASCII Setup), there still appears to be an interface problem between the sending device and the printer, read Appendix B.

Appendix C describes the Serial Interface Adapter option which is a rear extension board with jumpers that provides interface flexibility and convenience.

The serial ASCII signal is characterized by its baud rate, word length, parity type and number of stop bits. DIP switches on the printer allow the first three parameters to be matched to the incoming signal. The fourth parameter, the number of stop bits, is automatically matched by the printer.

The interface between the sending device and the printer normally requires two signal lines and a ground line. One signal line carries the serial ASCII data from the sending device to the printer and the other carries the BUFFER FULL handshake signal from the printer to the sending device.

The BUFFER FULL signal from the printer is used to inhibit further transmission of characters by the sending device. BUFFER FULL goes true during receipt of the first bit of the last character that the printer buffer can hold. The sending device completes the transmission of that character but sends no more characters until BUFFER FULL goes false. This occurs when the printer prints the next line and frees up the buffer space that contained the characters printed.

It may be possible to omit the BUFFER FULL handshake line at rates of 110 and 150 baud if there are more than 7 characters per line because the printer can print the characters faster than they are received. However, most of the printing time is consumed in advancing the paper, and fewer than 7 characters per line causes the printer to fall behind the input data and results in an occasional missed character. Therefore, it is recommended that the BUFFER FULL handshake signal be used even at the low baud rates.

An optional interface line is the printer-select line which may be used to remotely enable or disable the printer.

The pin assignments for these interface lines depend on the output logic type of the sending device. See also Pin Assignments, Section 3.3.

RS-232-C

Serial ASCII RS232C data
BUFFER FULL
 Ground

P1
3
20
7

RECEIVE DATA
 DATA TERMINAL READY (DTR)
 GROUND

20 mA Current Loop (Isolated)

Serial ASCII current source
 Serial ASCII current return
 Ground
BUFFER FULL (LSTTL)
BUFFER FULL (RS232C)

P1
12
24
7
11
20

DATA INPUT
 DATA RETURN
 GROUND
BUFFER FULL
 DATA TERMINAL READY (DTR)

TTL

Serial ASCII TTL data
 Ground (Tie 24 to 7)
BUFFER FULL

P1
12
24
7
11

DATA INPUT
 DATA RETURN
 GROUND
BUFFER FULL

LSTTL (Use Parallel ASCII Connector P9)**CMOS**

Serial ASCII LSTTL, CMOS data
 Ground
BUFFER FULL

P9
3
5
6

STROBE
 GROUND
BUFFER FULL

NOTE: For this logic type input, the serial ASCII signal must be inverted by setting DIP switch S5-3 ON.

For all of the above types a printer-select line is available on each connector for remote enable of the printer. An open PRINTER SELECT line enables the printer.

Printer Select
 (TTL or RS-232-C)

P1
6

DATA SET READY (DSR)

PRINTER SELECT
 (TTL)

P9
2

PRINTER SELECT

NOTE: All unused inputs should be left open.

Some sending devices may generate an inverted serial ASCII data signal. This can be properly received by the printer by setting DIP switch S5-3 ON.

After reading Section 3.6 (DIP Switches), see Section 3.8 for serial ASCII setup instructions.

3.5.3 Test Mode

In this mode, the Model 821 printer provides several self-diagnostic printout patterns for verifying proper operation or analyzing improper operation of the printhead and associated drive circuitry. Several different test patterns may be selected with the DIP switches.

Ripple Character Pattern

This pattern prints all of the available characters in sequence, 20 to a line, starting each line with the next character in sequence following the 1st character of the previous line.

All Dots, All Columns Pattern

This pattern prints all dots of the 5 x 7 matrix in all columns.

All Dots, 1 Column Pattern

This pattern prints all dots of the 5 x 7 matrix in one column.

Stepped Dots, All Columns Pattern

This pattern prints only one dot on each of the 7 lines of a character, stepping to the right 1 dot-column each time. This results in a diagonal line that wraps around because there are 7 dot-lines and only 5 dot-columns.

Stepped Dots, 1 Column Pattern

This pattern is the same as the previous except it appears in only 1 character-column.

After reading Section 3.5 (DIP Switches), see Section 3.9 for Test setup instructions.

3.6 DIP SWITCH FUNCTIONS

Certain parameters relating to the printer operating characteristics are controlled by the 8-position DIP switch S1 located on the front sub-panel board and the second 8-position DIP switch S5 and 4-position DIP switch S6 located on the main PC board. These parameters are entered into the microcomputer from the switch settings during power-up or reset. Once entered, changes in the switch settings have no effect on printer operation until the power is cycled off and on, or the reset pushbutton is operated. However, some of the switch positions are used to invert signal polarities and these are active at all times.

OFF	DIP SWITCH S1 (Front Sub-Panel)		ON	DESCRIPTION SECTION
	1	Baud-B1		3.6.1
	2	Baud-B2		3.6.1
	3	Baud-B4		3.6.1
	4	Parity-B1		3.6.2
	5	Parity-B2		3.6.2
	6	Auto Line Feed		3.6.7
Print Invalid Chars	7	Ignore Invalid Chars		3.4.3
Run	8	Test		3.9

OFF	DIP SWITCH S5 (Main Circuit Board)		ON	DESCRIPTION SECTION
Pos True ACK	1	Neg True ACK		3.6.10
Neg True BUFFER FULL	2	Pos True BUFFER FULL		3.6.10
Neg STROBE Pulse	3	Pos STROBE Pulse		3.6.10
Parallel ASCII Mode	4	Serial ASCII Mode		3.5
Text Printing	5	Data Printing		3.6.6
Pos. DATA Polarity	6	Neg. DATA Polarity		3.6.10
	7	Word Length-B1		3.6.3
	8	Word Length-B2		3.6.3

OFF	DIP SWITCH S6 (Main Circuit Board)		ON	DESCRIPTION SECTION
Disable RTS	1	Enable Request To Send		3.6.8
Neg True BUSY	2	Pos True BUSY		3.6.10
ASCII Characters only	3	ASCII + Special Chars		3.4.1
Not Serial TTL	4	Serial TTL		3.6.9

3.6.1 Baud Rate

In the Serial mode, the baud rate is selected by setting the baud rate switches according to the following table:

<u>Baud Rate</u>	<u>S1-3 Baud-B4</u>	<u>S1-2 Baud-B2</u>	<u>S1-1 Baud-B1</u>
110	0	0	0
150	0	0	1
300	0	1	0
600	0	1	1
1200	1	0	0
2400	1	0	1
2400	1	1	0
2400	1	1	1

"1" indicates switch is ON.

"0" indicates switch is OFF

3.6.2 Parity

In the Serial mode, parity is selected by setting the parity select switches according to the following table:

<u>Parity</u>	<u>S1-5 Parity-B2</u>	<u>S1-4 Parity-B1</u>
None	0	0
Odd	0	1
Even	1	0

"1" indicates switch is ON.

"0" indicates switch is OFF.

3.6.3 Word Length

In the Serial mode, the word length in bits is selected by setting the word-length switches according to the following table:

<u>Word Length</u>	<u>S5-8 Word Length-B2</u>	<u>S5-7 Word Length-B1</u>
6	0	0
8	0	1
7	1	0

3.6.4 Run/Test

The position of DIP switch S1-8 determines whether the printer is operating normally or in the self-test mode. When the switch is ON (Test selected), the printer operates in the Test mode. When the switch is OFF (Run selected), the printer operates in either the Parallel ASCII mode or the Serial ASCII mode depending on the position of DIP switch S5-4.

3.6.5 Parallel/Serial

The position of DIP switch S5-4 is set according to the type of input data being received. In the OFF position, the Parallel ASCII mode is selected and in the ON position, the Serial ASCII mode is selected. This selection is active only in the Run position of DIP switch S1-8.

If the Serial mode is selected, the baud rate, word-length and parity switches must also be set according to the characteristics of the sending device connected to the Printer.

3.6.6 Data/Text

The Data/Text switch S5-5 controls the direction of the printout. In the Data mode (S5-5 ON), each new line is printed above the preceding line, with the paper coming out downward. In the Text mode (S5-5 OFF) each line is printed upside down so that each new line is printed below the preceding line when the paper is inverted.

3.6.7 Auto Line Feed

DIP switch S1-6 controls the printer when it receives the character combination of carriage return and line feed (CR/LF). In the OFF position, it is assumed each line of text ends with the CR/LF combination; therefore, a LF following a CR is ignored since the CR character causes the printer to print a line. A LF character following any other character is processed normally. In the ON position, all LF characters are processed normally; therefore, a CR/LF combination will cause double spacing. The line of text in the buffer will thus be printed followed by a blank line.

3.6.8 Enable Request to Send

The BUFFER FULL signal for RS-232-C normally appears on connector P1, pin 20. However, due to the many configurations of sending devices, some expect to see the BUFFER FULL RS-232-C signal on connector P1, pin 4 (see Appendix B). To achieve this, DIP switch S6-1, Enable Request To Send, is set ON. If the sending device does not expect the BUFFER FULL handshake signal on P1, pin 4 then DIP switch S6-1 should be set OFF to open the line and prevent interference with another function of the sending device.

3.6.9 Serial TTL

When the serial ASCII data type is TTL, it is applied directly to the input diode of the opto-isolator. DIP switch S6-4 is turned ON to provide a pull-up resistor for this circuit. A TTL circuit does not source enough positive current to turn on the opto-isolator so an additional 10 mA is supplied through the pull-up resistor. When the data type is not TTL, DIP switch S6-4 must be turned OFF.

3.6.10 Logic Polarities

Certain DIP switches provide inversion of the logic polarities of the interface circuits. These are hardware inversions that become effective at the instant the DIP switch is activated.

<u>ACK</u>	S5-1 OFF	<u>ACK</u>	S5-1 ON
<u>BUFFER FULL</u>	S5-2 OFF	BUFFER FULL	S5-2 ON
<u>STROBE</u>	S5-3 OFF	STROBE	S5-3 ON
<u>BUSY</u>	S6-2 OFF	BUSY	S6-2 ON

One other DIP switch, S5-6, when ON, provides for positive-true data lines in the Parallel ASCII mode and when OFF provides for negative-true data lines. The printer must be RESET or the power cycled OFF and ON to make this switch setting effective.

3.7 PARALLEL ASCII SETUP

Refer to Section 3.5.1 for a description of the Parallel ASCII mode.

- (1) Connect the eight input data lines to Data Bit 0 (LSB) through Data Bit 7 (MSB) of P9 (see pin assignment list, Section 3.3). Since the ASCII code is only a 7-bit code, it is not necessary to connect to Data Bit 7 because that bit is ignored. Select the logic polarity of the input data as follows:

INPUT SIGNALS	SWITCH	POS TRUE	NEG TRUE
DATA Polarity	S5-6	OFF	ON

- (2) Referring to Section 3.5.1, determine which handshake signals are compatible with the sending device and connect them. Then select the desired logic polarity according to the following table.

HANDSHAKE SIGNALS	SWITCH	POS TRUE	NEG TRUE
ACKNOWLEDGE	S5-1	OFF	ON
BUFFER FULL	S5-2	ON	OFF
STROBE	S5-3	ON	OFF
BUSY	S6-2	ON	OFF

- (3) Select the Parallel ASCII mode by selecting the following switch positions.

FUNCTION	SWITCH	POSITION
Parallel ASCII Mode	S5-4	OFF
Run	S1-8	OFF
Not Serial TTL	S6-4	OFF

- (4) The DIP switches for other functions have optional settings, set them as desired (see Section 3.6, DIP SWITCH FUNCTIONS).

SWITCH	FUNCTION
S1-6	ON = Execute all line Feeds (LF).
	OFF = Execute all line Feeds (LF) except those that immediately follow a Carriage Return (CR).
S1-7	ON = Ignore invalid characters.
	OFF = Print invalid characters in reverse field blocks.
S5-5	OFF = Text Mode
	ON = Data Mode
S6-3	OFF = ASCII Characters Only
	ON = ASCII + Special Characters

3.8 SERIAL ASCII SETUP

Refer to Section 3.5.2 for a description of the Serial ASCII mode.

- (1) Connect the Serial ASCII data input and BUFFER FULL handshake lines for the appropriate logic type signal (RS-232-C, 20 mA current loop, TTL, LSTTL or CMOS) as shown in Section 3.5.2. It may be necessary to refer to Appendices B and C for additional information on interfacing with Serial ASCII data.

Set DIP switch S6-4 as follows:

SWITCH	FUNCTION
S6-4	ON = Logic type TTL OFF = Logic types RS-232-C, 20 mA Current Loop, LSTTL and CMOS

NOTE: If the sending device is transmitting an inverted Serial ASCII data signal, it is necessary to turn DIP switch S5-3 ON (except for logic types LSTTL and CMOS).

- (2) The only handshake line that is normally used with a Serial ASCII interface is BUFFER FULL and the sending device almost always requires a negative true polarity. However, if necessary, a positive true polarity may be selected.

HANDSHAKE SIGNAL	SWITCH	POS TRUE	NEG TRUE
BUFFER FULL	S5-2	ON	OFF

- (3) Select the Serial ASCII mode by setting the following switch positions.

FUNCTION	SWITCH	POSITION
Serial ASCII Mode	S5-4	ON
Run	S1-8	OFF
Serial ASCII data polarity	S5-3	OFF See Note in (1) above

- (4) Program the baud rate, parity and word length according to the following tables. It is not necessary (nor possible) with the Model 821 Printer to program the number of stop bits.

SWITCH	BAUD RATE					
	110	150	300	600	1200	2400
S1-1	OFF	ON	OFF	ON	OFF	ON
S1-2	OFF	OFF	ON	ON	OFF	OFF
S1-3	OFF	OFF	OFF	OFF	ON	ON

SWITCH	PARITY		
	None	Odd	Even
S1-4	OFF	ON	OFF
S1-5	OFF	OFF	ON

SWITCH	WORD LENGTH		
	6	7	8
S5-7	OFF	OFF	ON
S5-8	OFF	ON	OFF

- (5) Program the remaining DIP switches as required.

SWITCH	FUNCTION
S1-6	ON = Execute all line Feeds (LF).
	OFF = Execute all line Feeds (LF) except those that immediately follow a Carriage Return (CR).
S1-7	ON = Ignore invalid characters.
	OFF = Print invalid characters in reverse field blocks.
S5-5	OFF = Text Mode
	ON = Data Mode
S6-3	OFF = ASCII Characters Only
	ON = ASCII + Special Characters

- (6) Press the RESET button or turn the Printer power off and on to enter the switch settings into the microcomputer.

3.9 TEST SETUP

The front sub-panel DIP switch S1 is used to select the Test mode and the desired test pattern (Figure 3.6).

<u>S1 POS 8</u>	<u>S1 POS 1</u>	<u>S1 POS 6</u>	<u>S1 POS 7</u>	<u>PATTERN DESCRIPTION</u>
1	1	X	X	Ripple character
1	0	0	0	All dots, one col
1	0	0	1	Stepped dots, one col
1	0	1	0	All dots, all cols
1	0	1	1	Stepped dots, all cols

"1" indicates the switch is on.

"0" indicates the switch is off.

"X" indicates the switch may be either on or off (don't care condition).

TEST PATTERN CONTROL

In the Self-Test Mode the functions of the print and Feed pushbuttons are re-defined as follows:

- PRINT - Pressing this pushbutton causes the printer to alternately start and stop printing.
- FEED - Pressing this pushbutton provides normal paper advance when either the printer is not printing or when it is printing the ripple character or the all-column pattern. When printing either of the one-column patterns, pressing the feed pushbutton causes the column in which the test character is being printed to shift right one column, wrapping around to column 1 after printing column 20.

STEPPED DOTS / ALL COLUMN PATTERN

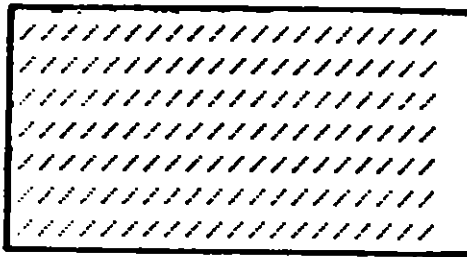

- OFF 1
- OFF 2
- OFF 3
- OFF 4
- OFF 5
- 6 ON
- 7 ON
- 8 ON

DIP Switch S1

STEPPED DOTS / ONE COLUMN PATTERN

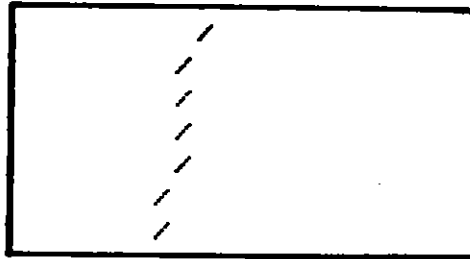

- OFF 1
- OFF 2
- OFF 3
- OFF 4
- OFF 5
- OFF 6
- 7 ON
- 8 ON

DIP Switch S1

ALL DOTS / ALL COLUMNS PATTERN

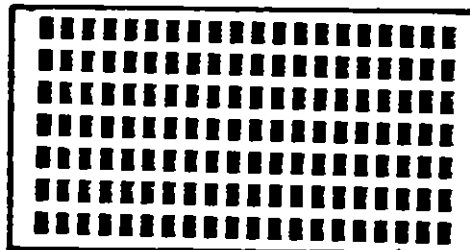

- OFF 1
- OFF 2
- OFF 3
- OFF 4
- OFF 5
- 6 ON
- OFF 7
- 8 ON

DIP Switch S1

ALL DOTS / ONE COLUMN PATTERN

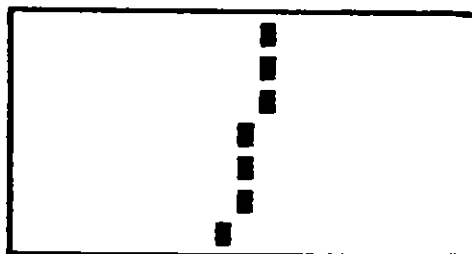

- OFF 1
- OFF 2
- OFF 3
- OFF 4
- OFF 5
- OFF 6
- OFF 7
- 8 ON

DIP Switch S1

RIPPLE CHARACTER PATTERN

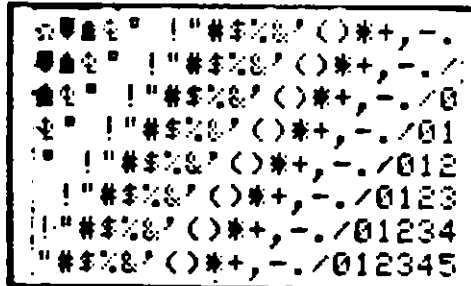

- 1 ON
- OFF 2
- OFF 3
- OFF 4
- OFF 5
- OFF 6
- OFF 7
- 8 ON

DIP Switch S1

Test Patterns
Figure 3.6

4.0 THEORY OF OPERATION

4.1 PRINTHEAD OPERATION

The printhead consists of a row of 100 silicon mesa elements arranged in 20 groups of 5. When current passes through these elements, the generated heat darkens the thermal paper to form a row of dots. The paper is advanced seven times to generate seven rows of dots and form 20 characters across the paper, each composed of a 5 x 7 dot matrix. The paper is then advanced three blank dot rows to form the space between lines. Whenever a lower case character with descenders (eg. p, q) is printed, the descending portion of the character extends down two of these three rows.

When a line of characters is ready to be printed, the first (left-hand) dot of each column is printed first. Character look-up tables determine the presence or absence of first dots in each character position of the first row. First dot information for the first 5 columns is latched into U7, the next 5 columns into U8, the next 5 columns into U9 and the final 5 columns remains latched on the output of the microcomputer U3, PC0 to PC4. Next, EA1 of U11 goes true to fire SCR CR1 to apply +16 V to the first element of each column. Darlington transistors U2 to U5, as driven by the latches, will ground the other end of those elements that are to burn a dot and will be an open circuit to those that are not to burn a dot.

This process is continued for the second dot in each column by firing SCR CR2. After the fifth dot is printed by firing CR5, the first row is complete and a two-phase signal is applied to the motor through Q2-Q5. This advances the paper one dot row and the above process is repeated for the second row. After 7 rows of printing, the paper advances 3 blank rows (which could include 2 more rows of printing if there are lower case descenders).

The +16 V applied to the elements through the SCR's is actually a full-wave rectified sine wave. The intensity of the dot is determined by the phase angle at which the SCR is fired. The intensity control, accessible at the rear panel, varies the duration of a delay circuit in the power supply. The output of this circuit is the COMPARATOR (COMP) signal that is applied to U1 and U12 to control the firing angle of the SCR's.

4.2 MOTOR DRIVE

One set of two-phase drive pulses applied to the motor, advances the paper one dot-row. The two windings are driven in both directions by Q2-Q5 from signals originating in the microcomputer.

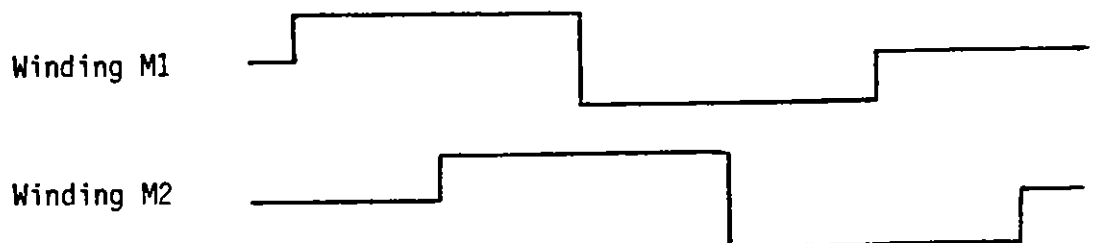

An enable signal is capacitively coupled (C5) to U6 of the motor drive circuit to prevent the motor winding from burning out, should a steady drive signal be present due to a malfunction of the microprocessor.

4.3 DIP SWITCHES

When the microcomputer is reset, either with the front sub-panel RESET switch or during power-on, the program goes through its initiating sequence and reads the position of the DIP switches. This information, along with parallel ASCII data, is multiplexed under control of PC6, PD6 and PD7 into port B (PBO-PB7) of the microcomputer.

PC6 high, PD6 high, PD7 low: Read S1-1 to S1-6, S5-7, S5-8.

PC6 high, PD6 low, PD7 high: Read S1-7, S1-8, S5-4 to S5-6, S6-3.

PC6 low, PD6 and PD7 high or low: Read parallel input data.

The remaining DIP switch positions are hardware related and are not read by the microcomputer.

4.4 PARALLEL ASCII INPUT CIRCUITS

Parallel input data is strobed by the Sending Device into the 8-bit latch U20 where it is read by the microcomputer. S5-3 and Exclusive-or gate U25 provide acceptance of either polarity of the Strobe pulse.

Receipt of a Strobe pulse sets RS flip-flop U24 to create an immediate Busy signal. Either polarity may be generated by switch S6-2 and U25. The RS flip-flop is reset by the Acknowledge pulse created by the microcomputer after the input data has been accepted. Either polarity of Acknowledge pulse is provided by switch S5-1 and U25. A Buffer Full signal is generated by the microcomputer on port PA5 when the 41-character buffer has filled. Either polarity is provided by switch S5-2 and U25.

A printer remote enable signal is applied to port PA7. An open circuit or high level constitutes an enable state.

4.5 SERIAL ASCII INPUT CIRCUITS

Serial input data is normally received on pin 3 of P1 with jumper W4 in place. If the Sending Device is transmitting data on pin 2, jumper W5 may be added or a Serial Interface Adapter board (see Appendix C) inserted between the cable and the printer.

The 20 mA current loop data is received on pin 12 of P1 and returned on pin 24. It is converted to voltage levels by the opto-isolator U22.

TTL data inputs are also applied to pin 12 of P1 but pin 24 must be connected to ground (pin 7). In addition, DIP switch S6-4 must be closed to add a pull-up resistor (R34) for supplying positive current to the opto diode.

Since received data goes through the Exclusive-or gate U25, controlled by switch S5-3, this switch may be used to invert the data, if required.

CMOS, TTL or low-power-Schottky TTL input signals may be applied to pin 3 of P9 which goes to a low-power-Schottky gate.

5.0 MAINTENANCE AND TROUBLESHOOTING

5.1 FRONT SUB-PANEL ACCESS

It is necessary to remove the front plastic bezel to operate the RESET pushbutton, set DIP switches S1 and to replace the paper. To remove the plastic front bezel, press in at the middle of both sides, close to the main housing. Pull the bezel away from the housing as you continue to squeeze in on the two sides.

To replace the front bezel, squeeze in on the two sides, push it up against the main housing and release. Be sure the paper is advanced far enough to feed it through the exit opening of the bezel as you replace it.

5.2 MAIN CIRCUIT BOARD ACCESS

It is necessary to remove the complete Printer Assembly from the case to set DIP switches S5 and S6.

To remove the Printer assembly from the case, first disconnect the power. Then remove the four corner screws from the rear panel and slide the entire assembly out the rear of the housing.

***** CAUTION *****

If power to the Printer has been on prior to removing it from the case, be careful to avoid touching the power transformer laminations or the 7.5 ohm, 5W power resistor next to the transformer. Either could be hot enough to burn the skin.

If the assembly was removed to setup the DIP switches, it may be desirable to operate the Printer outside of its housing until the correct switch settings have been determined. Since all of the circuitry is exposed, take extreme care to prevent contact with conductive tools, cases, etc. The paper will not feed properly if the Printer assembly is setting flat on the bench, so put a narrow prop (eg. a wooden pencil) under the print mechanism just below the center of the roller.

Once the DIP switches have been properly set, disconnect the power and return the assembly to its housing.

To replace the assembly in its housing, slide the front of the assembly into the rear opening of the housing, making sure that the main circuit board is in the top slot of the housing. Push the assembly completely into the housing and replace the four screws in the corners of the rear panel.

5.3 PAPER INSTALLATION OR REPLACEMENT

Most thermal papers have a colored stripe near the end of the roll (approximately 25 feet for Newport paper). The printer also has a red LED out-of-paper indicator.

To replace the paper, first remove the front bezel by pressing in on both sides and pulling out. Press down on the plastic projection on the lower right hand side to free the print mechanism.

Lift up on the mechanism until the straight wire on the right side engages the catch and the mechanism stays up.

Reach in and pull out the paper holder. Remove the old paper core and discard, keeping the plastic tube. Insert this tube in a new roll of paper and mount in the paper holder, making sure the holder pins are properly seated in the ends of the plastic tube. The heat sensitive side of the paper faces out. Unroll a few inches of paper from the new roll. Thread the paper so that it comes down between the roll and the front bar of the holder.

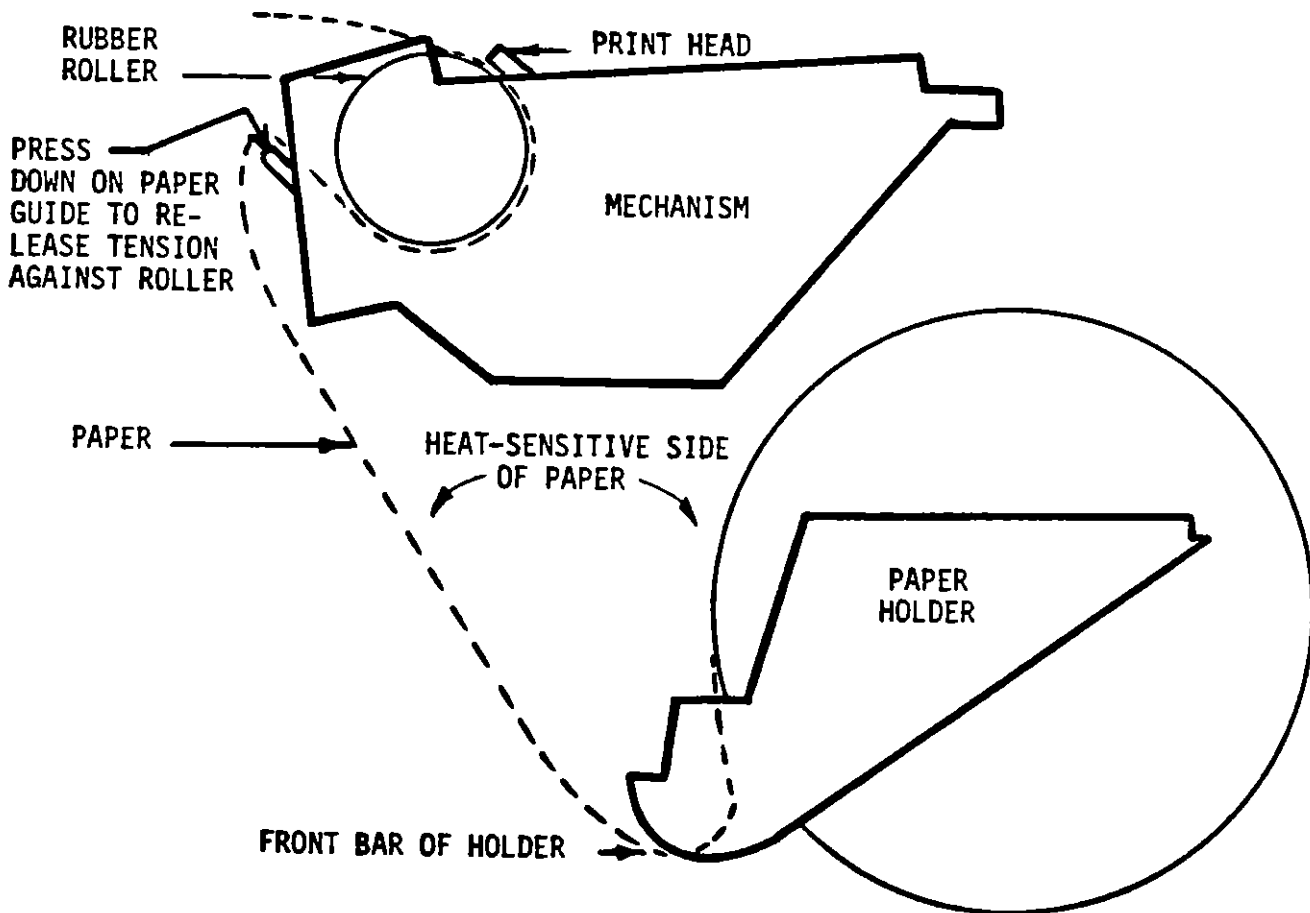

Paper Replacement
Figure 5.1

The heat sensitive side of the paper should contact the rounded edge of the holder. Pull the paper under the rounded edge at the front of the holder and then up to form a leader to thread the mechanism.

Insert the paper into the space between the paper guide and the roller as far as it will go and then push and hold down the FEED button. The paper should self-thread and emerge from under the printhead. If the friction of the roller doesn't catch the paper to pull it through, press down on the paper guide to release the tension against the roller and insert the paper further into the opening. Now, when the paper guide is released and the FEED button pushed, it will reliably catch and self-feed.

Lift up on the wire on the right side of the print mechanism to release the catch and return the mechanism to its normal position. Hold the FEED button down to take up the slack created by lowering the print mechanism. Slack paper will occasionally cause printing of uneven characters. This will clear up as soon as the slack is removed. Erratic operation will also occur if there is too much tension on the paper. Check for binding in the paper path.

***** CAUTION *****

Never pull the paper through the mechanism. This can cause damage to the motor gear-train. Always use the FEED pushbutton to advance the paper or push down on the paper guide to release the tension for removing paper remnants.

5.4 CLEANING THE PRINTHEAD

During printing, the heat of the dots tends to cause the printhead to stick to the paper. A small "pop" is heard as each line of dots breaks away from the paper. Loud "pops" indicate that the dot intensity adjustment is set too high. The use of low temperature papers or printing too dark may gum up the printhead with residue from the paper coating. Faded streaks will then appear on the printout. Advance the paper several inches without printing and the head may clean itself. If it doesn't, follow method (1) below. If the symptom still persists, follow method (2).

- (1) Remove the thermal paper from the roller and insert a strip of bond paper 1-1/4 to 2-1/2 inches wide. Run the bond paper through the printer by pushing the FEED pushbutton. This may be repeated several times. The roughness of the bond paper should remove the residue from the printhead.

If printing is attempted on the bond paper, the heat will soften the residue on the printhead and facilitate its removal.

- (2) Insert the corner of a business card underneath the printhead by pressing down on the paper guide until the card is inserted and then releasing the paper guide. It is not necessary to remove the thermal paper. Slide the card from side to side several times, remove and print the test pattern to check the results. Repeat if necessary. If this is done while the Printer is printing, the heat of the printhead will soften the residue and facilitate its removal. However, be careful not to interfere with the normal rotation of roller so the gear train will not be damaged.

***** CAUTION *****

Never use excessive dot intensity. Not only will the noise increase and the printhead gum up but the printhead could be damaged. On the printhead, the dots are cemented to the ceramic substrate with epoxy cement. Excessive heat will shorten the life of the printhead by making the epoxy cement dark and brittle.

5.5 PRINTING MECHANISM

Keep the motor, gear train, roller and other parts of the mechanism clean and free from dust. Clean with compressed air and/or camels-hair brush. Use only alcohol as a solvent applied with a cotton swab.

The motor and pinion have lifetime oilite bearings. For particularly heavy usage, the gear bearings may be oiled once a year with CHEMLUBE 645 (ULTRACHEM, INC.). Apply sparingly with a hypodermic needle applicator; excess oil is only a dust collector.

5.6 TROUBLESHOOTING

If the Printer fails to function properly, remove the rear connector and put the Printer in the TEST mode (Sections 3.5.3 and 3.9). The test patterns may help diagnose the problem. If the TEST mode functions properly, it is likely to be an external interface or DIP switch setup problem. A number of possible symptoms and their probable causes are given in the troubleshooting guide below.

<u>Symptom</u>	<u>Possible Causes</u>
(1) Green LED not on when power applied.	Fuse blown.
(2) Red LED not on when paper out.	*Opto-detector defective.
(3) Red LED on with paper installed.	Paper not installed correctly. Paper torn. Paper guide sticking open. *Opto-detector defective.
(4) Paper has torn or frayed edges.	Paper not installed properly. Roller or paper binding. Excessive paper width. *Gears binding or stripped.
(5) Paper doesn't advance when FEED is pushed.	Same as (4). Power not on or printer needs resetting.
(6) Paper doesn't advance during expected printing.	Intensity adjustment too high and paper sticking. Printer needs to be reset. PRINT button not pushed after replacing paper. Same as (4).

*Factory repair

- | | |
|--|---|
| (7) Paper advances during printing but is blank. | Intensity adjusted too light.
Paper installed wrong side out
(thermally sensitive side against roller). |
| (8) TEST mode doesn't work. | RESET button wasn't pushed after DIP switch selection of TEST mode. |
| (9) Difficult to stop printing in TEST mode. | *Dirty PRINT switch causes excessive contact bounce on "stop" release that starts it printing again. |
| (10) Printer does not respond to input data. | Input data and parameter (DIP switch) setup not compatible.
Printer waiting for data.
Printer needs to be reset.
*Circuit malfunction. |
| (11) Dot column(s) prints light. | Printhead dirty (see Section 5.4).
Dot intensity adjusted too light.
*Defective printhead.
*Spring tension incorrect. |
| (12) Paper does not emerge centered under printhead. | Not enough paper advanced (approximately 2 feet) to allow self-centering.
One end of paper holder out of its track. |
| (13) Data runs together with no LF or CR. | CR character missing at the end of each line of data. |
| (14) Blank line between printed lines. | CR/LF characters at end of each line and S1-6 ON. |
| (15) Missing characters. | See Appendix B.7 |

*Factory repair

Troubleshooting Guide

Table 5.1

6.0 DRAWINGS
SCHEMATIC DIAGRAM 821 PRINTER PROCESSOR

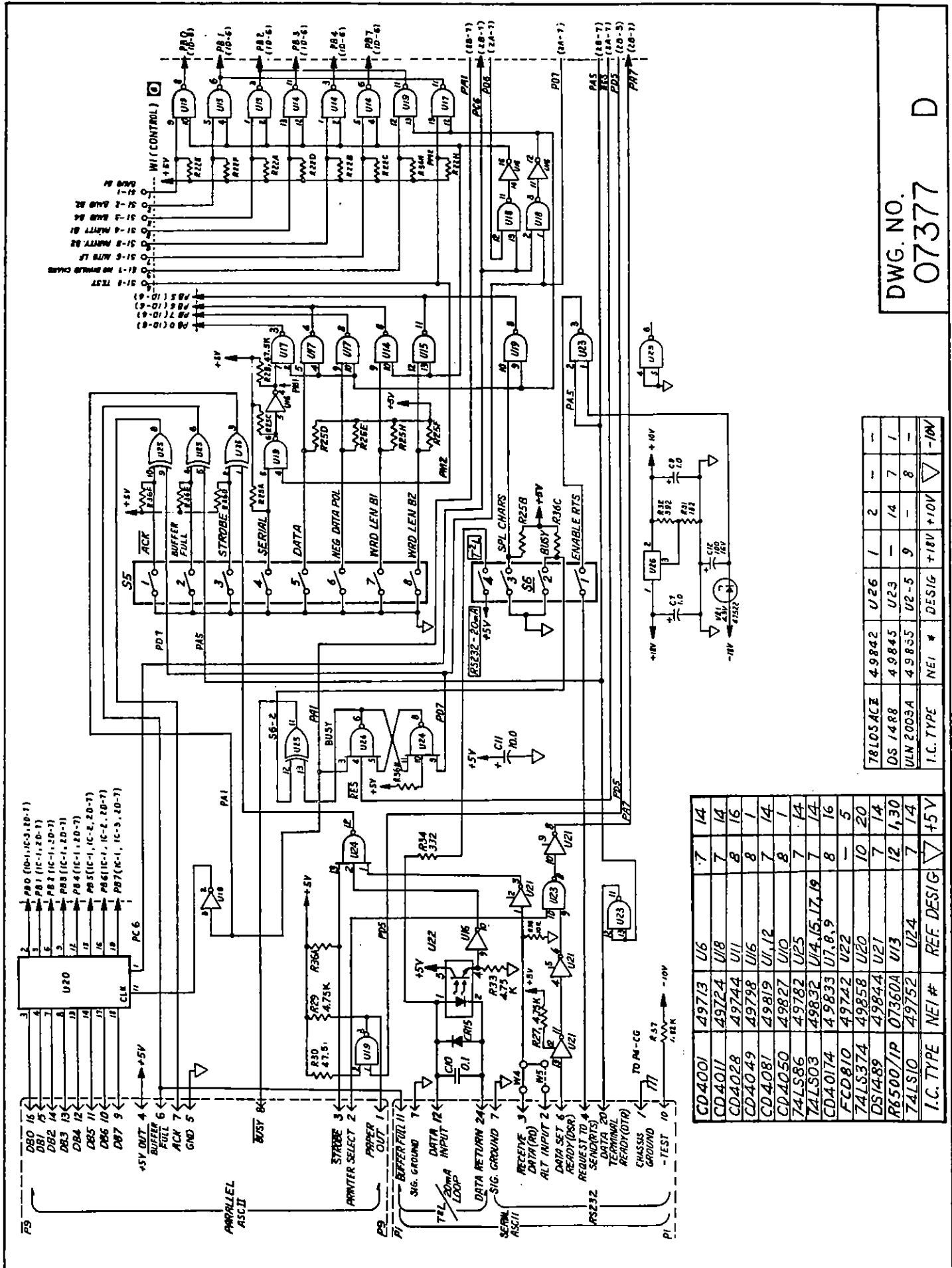

DWG. NO.
07377
D

78L05ACZ	4.9842	U26	1	2	-
DS 1488	4.9845	U23	-	14	7
ULN 2003A	4.9855	U2-5	9	-	8
I.C. TYPE	NEI *	DESIGN	+18V	+10V	-10V

CD4001	49713	U6	7	14
CD4011	49724	U18	7	14
CD4028	49744	U11	8	16
CD4049	49798	U16	8	1
CD4081	49819	U1,12	7	14
CD4050	49827	U10	8	1
74LS86	49782	U25	7	14
74LS03	49832	U14,15,17,19	7	14
CD40174	4.9833	U1,8,9	8	16
CD40810	49742	U22	-	5
74LS374	49858	U20	10	20
DS1489	49844	U21	7	14
R6500/1P	07360A	U13	12	1,30
74LS10	49752	U24	7	14
I.C. TYPE	NEI #	REF. DESIGN	▽	+5V

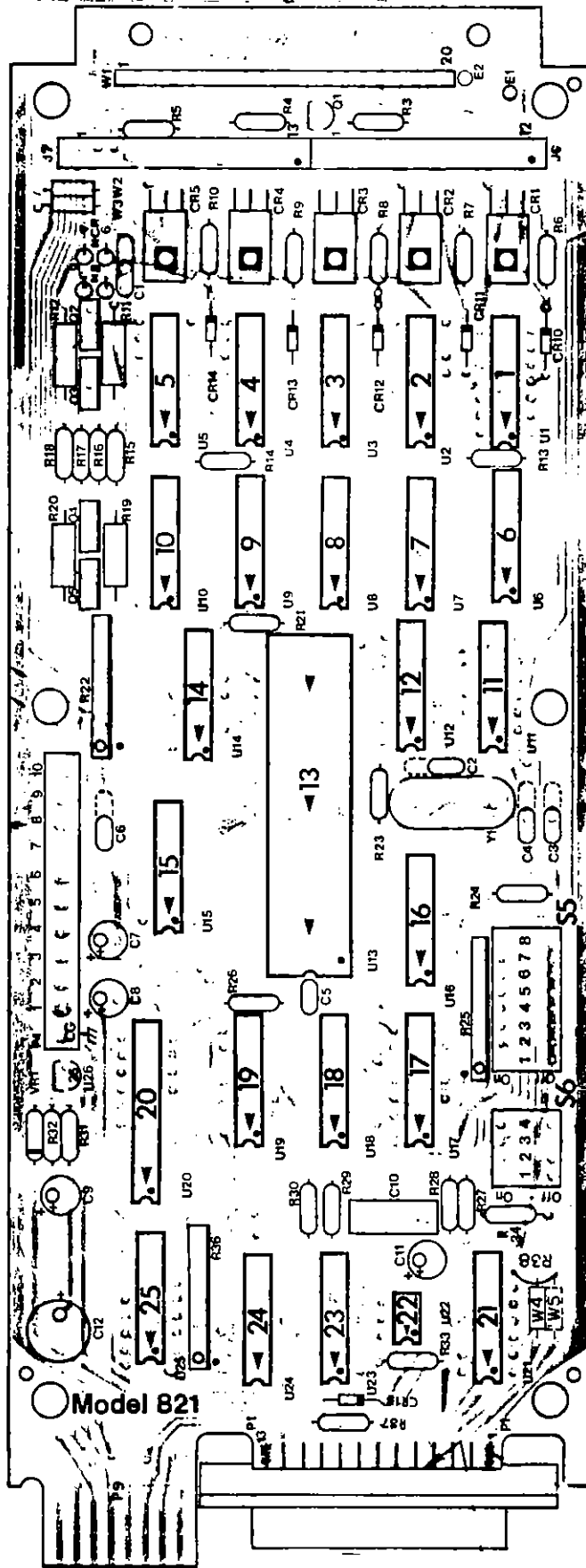

DWG. NO.
07375-00 C

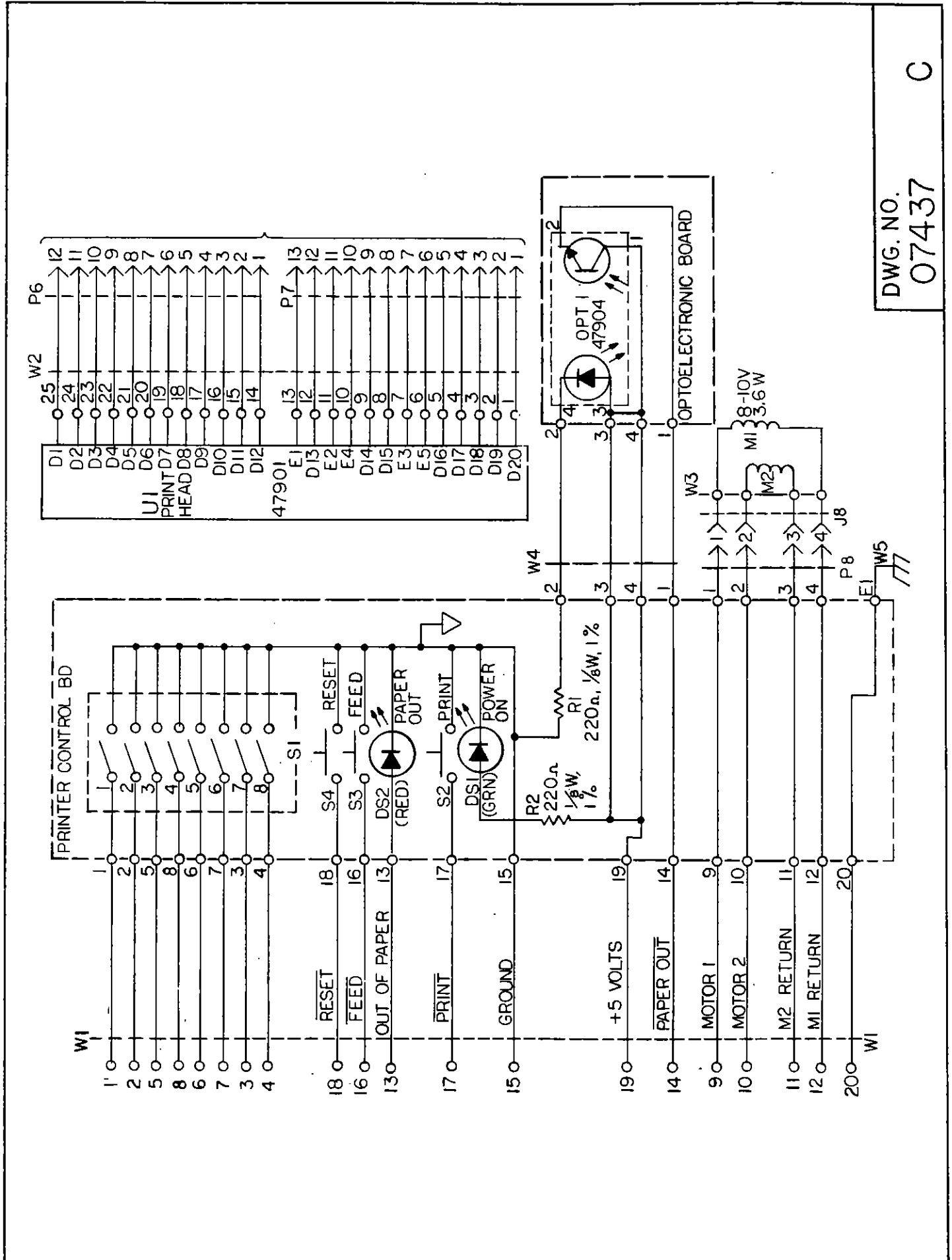

DWG. NO.
07437

C

DWG. NO.
07435AY-01 A

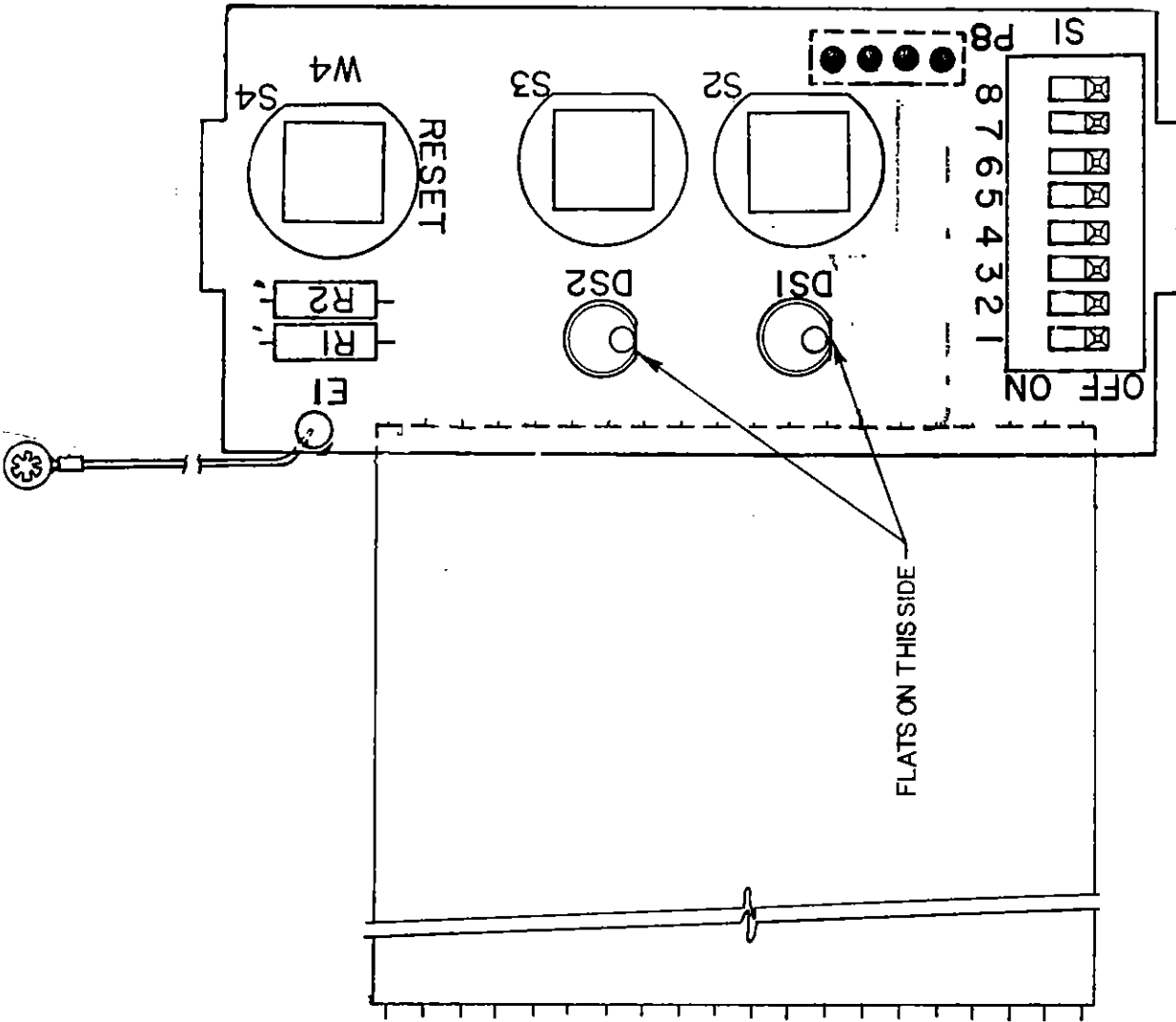

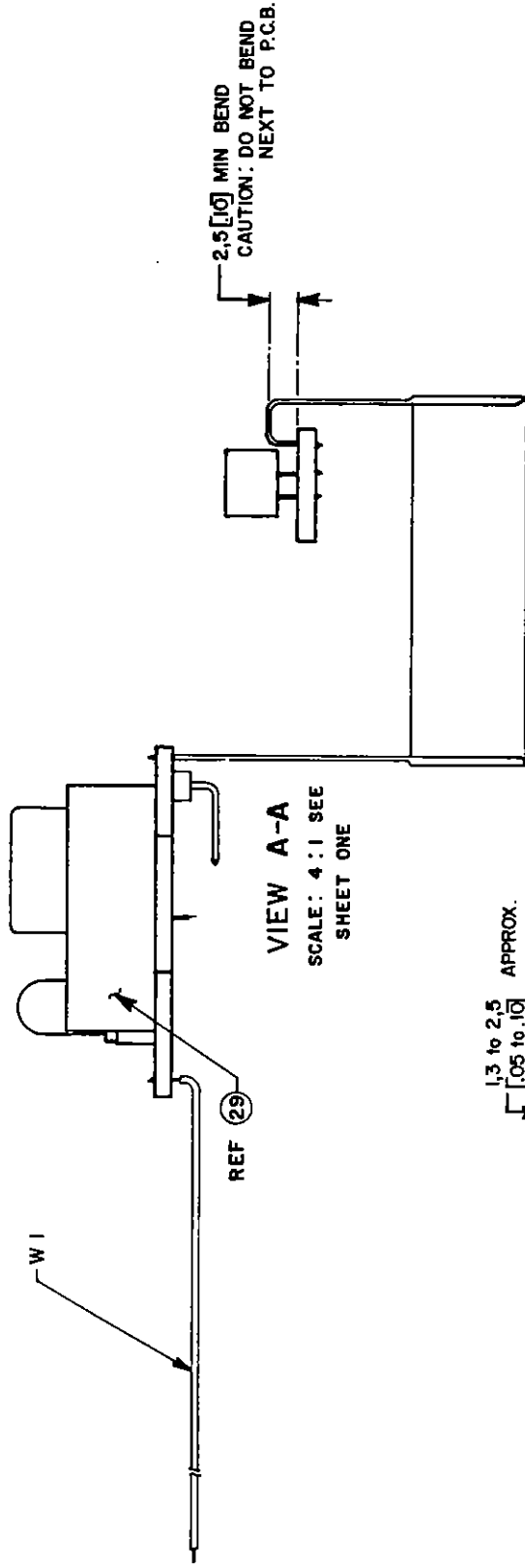

VIEW A-A
SCALE: 4:1 SEE
SHEET ONE

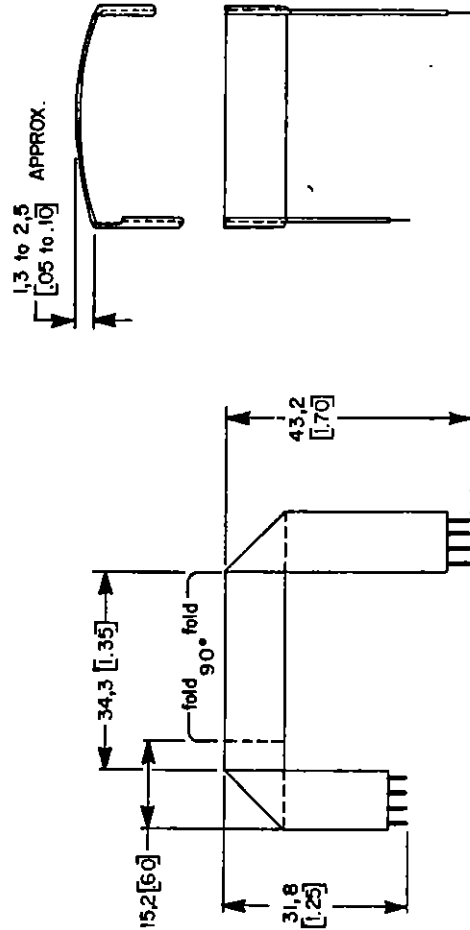

FOLDED FLAT

DWG. NO.
07435AY-01 A

DWG. NO.
07400AY-01 B

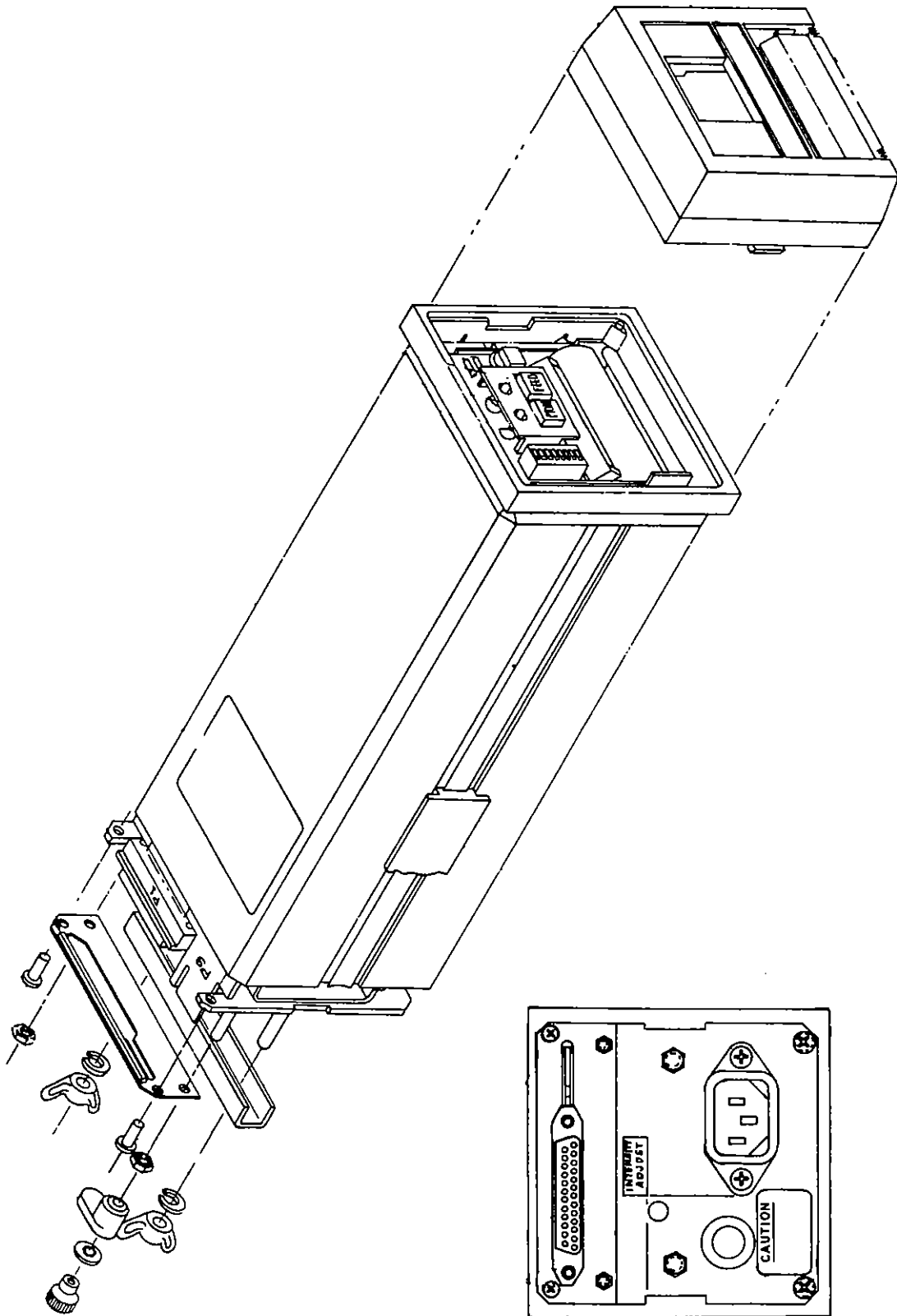

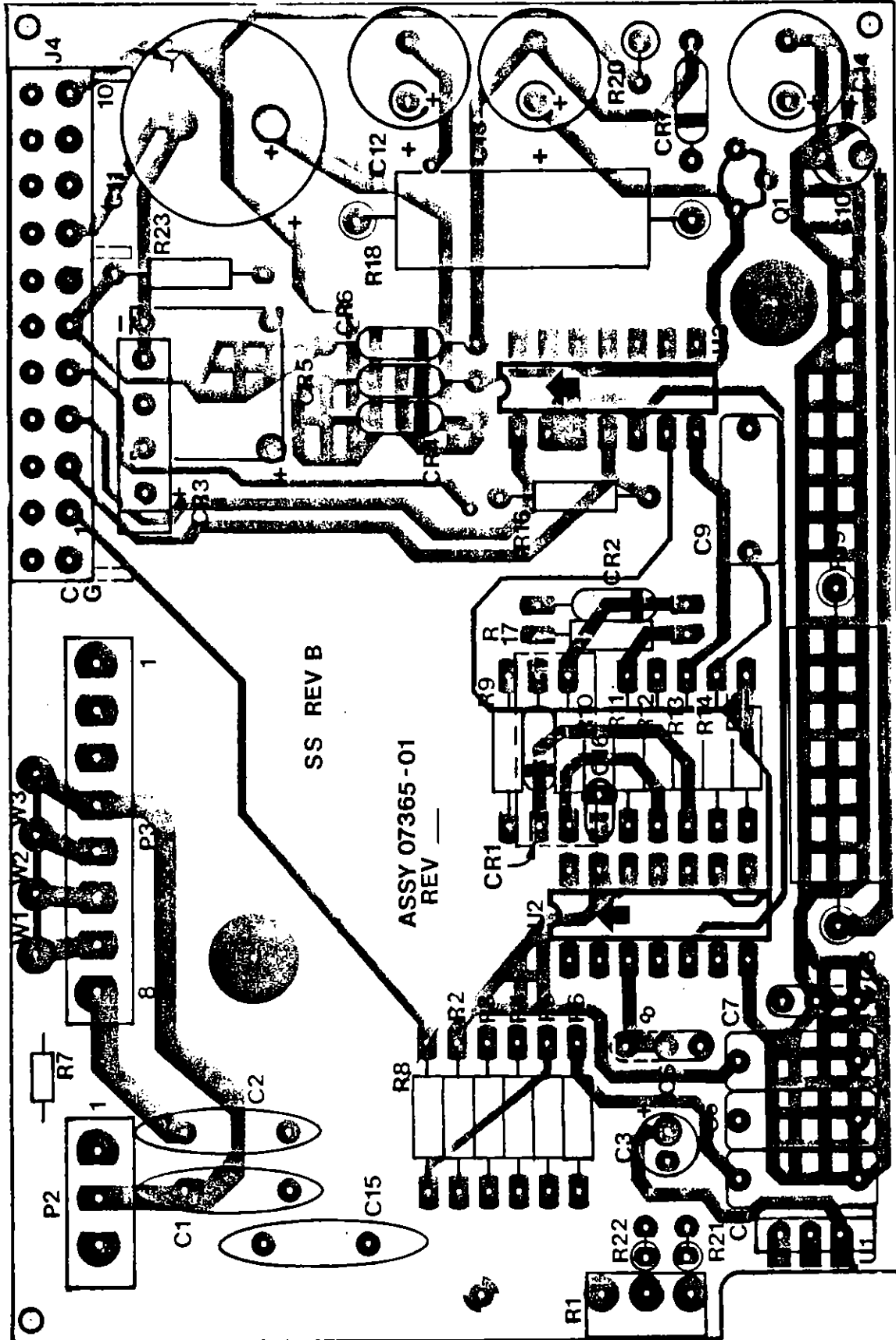

DWG. NO.
07365AY-01 D

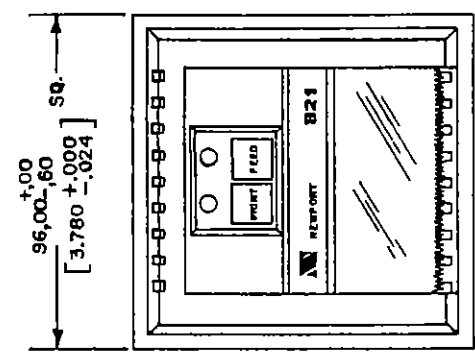
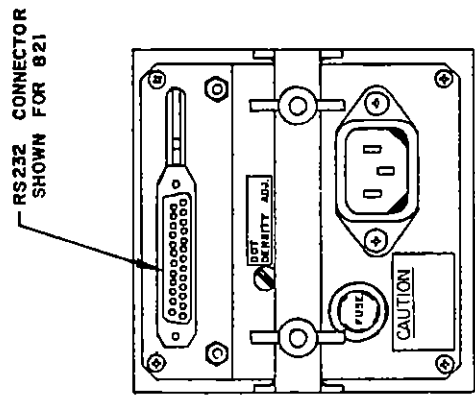
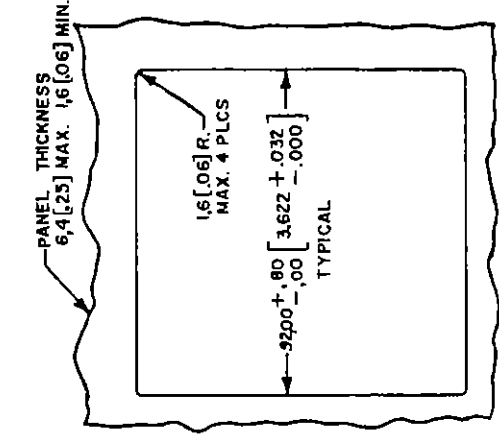
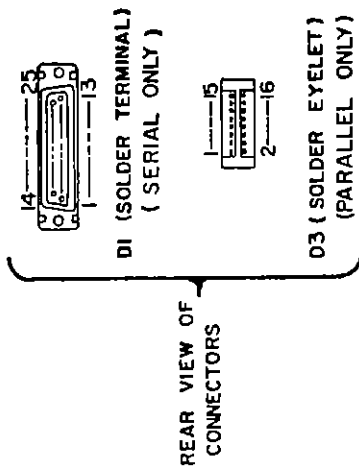
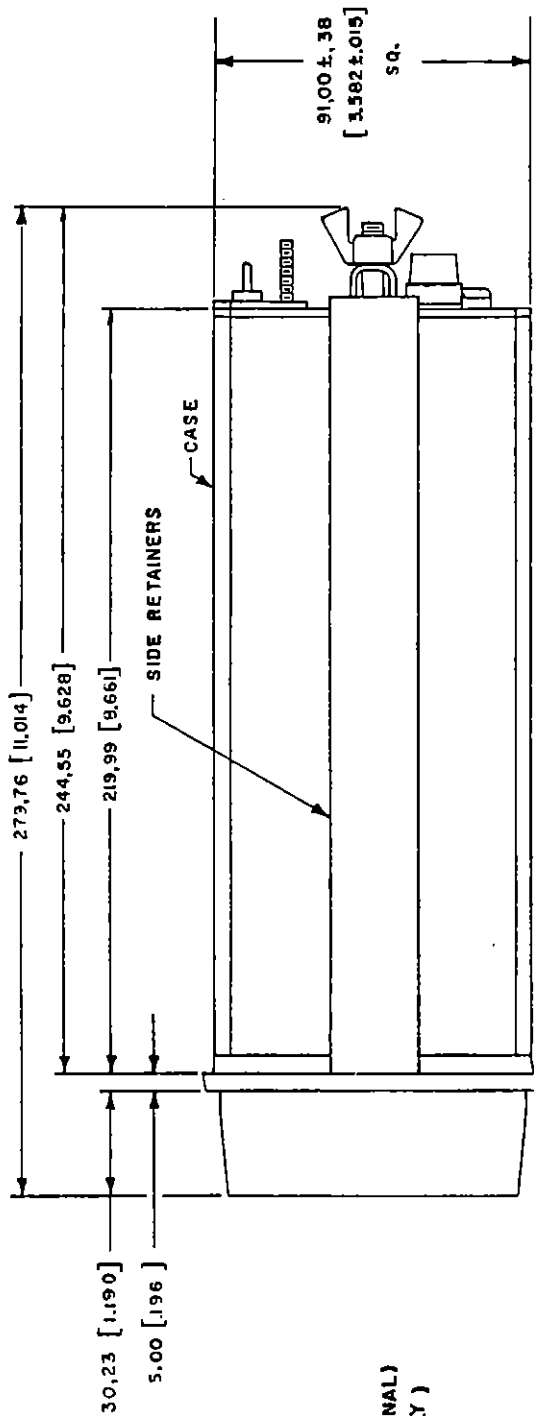

DWG. NO.
 07296-01 A

APPENDIX A

DEFINITION OF TERMS

The following is a list of definitions for the terms commonly used in data communications and interfaces.

Data Communication	Communication between digital devices that takes place via transmission of coded messages consisting of bits.
Bits	The bit is the smallest part of a coded message. The bit is a unit of information that has only two states (binary). These states may be on/off, high/low, true/false, current/no current, and so forth. Bits are grouped together to form message characters.
Byte	A group of bits treated as a message character is called a byte. Generally, a byte consists of a group of 8 bits.
Codes	Information is transmitted by means of message characters consisting of coded bits. Some of the common codes used in data transmission are straight binary, octal, binary-coded-decimal (BCD), hexadecimal, ASCII, Baudot and EBCDIC.
Straight Binary	A straight binary transmission is a string of bits representing coded message characters. When strings become long, like 001010110101, it is difficult to read them. Therefore, an octal code is sometimes used.
Octal	An octal code breaks up a binary number into groups of three bits. Three binary bits represent the states 0 to 7. The binary number above converts to the octal number 1265. $\begin{array}{cccc} \underline{001} & \underline{010} & \underline{110} & \underline{101} \\ 1 & 2 & 6 & 5 \end{array}$
BCD	Binary-coded-decimal (BCD) uses groups of 4 binary bits to represent the decimal numbers 0 through 9. Since 4 binary bits can represent numbers from 0 through 15, the codes 10 through 15 are illegal in BCD transmission.
Hexadecimal	This code also uses 4 bits to define a character, but all states are allowed. The numbers 0 through 9 remain and 10 through 15 are represented by A through F respectively.

ASCII	The American Standard Code For Information Interchange (ASCII or sometimes USASCII) is a 7-bit code for alphanumeric communication. The ASCII code is shown in Table 3.1 of the manual. Many devices use only a part of the ASCII character set. A common example is alphanumerics with upper case letters only.
Baudot	A five-bit code used mainly in telegraphy.
EBCDIC	An eight-bit code to which a parity bit is added to provide a nine-track format for digital magnetic tape.
Parallel ASCII	All bits of the ASCII-coded message character appear simultaneously in parallel on 7 lines. An eighth line may be present to complete the byte, but is ignored. This is sometimes referred to as Bit-Parallel, Byte-Serial or Centronics-Parallel.
Serial ASCII	Each bit of the ASCII-coded message character is transmitted in sequence on one line (plus a ground return). It is sometimes called Bit-Serial. Additional bits are supplied to the 7-bit code to distinguish the start and stop of each message character. RS-232-C communication uses Serial ASCII transmission. See Appendix B.
Baud	In Bit-Serial (eg. Serial ASCII) communication, baud (sometimes inaccurately called baud rate) is the bit rate of the channel. It is the rate at which the consecutive bits within a message character are transmitted. The character rate is a function of the number of bits associated with the character. For example, if a Serial ASCII system uses 1 start bit + 7 data bits + 1 parity bit + 2 stop bits, each character is composed of 11 bits. Thus, 110 baud = 10 characters per second. Common rates are 110, 150, 300, 600, 1200, 2400, 4800 and 9600 baud.

Parity	<p>A parity bit is used to provide some error detection capability in the transmission of data.</p> <p>Parity, when used, can be odd or even. For even parity, the sender counts the number of 1-bits in each character. If the total number of 1-bits is even (0, 2, 4, etc.), then the parity bit is made a binary 0 to keep the total even. If the total number of 1-bits is odd, the parity bit is made a binary 1 to restore the total number of 1-bits to an even number.</p> <p>Odd parity is the opposite of even. The sender makes the parity bit a 1 or zero to keep the total number of 1-bits odd.</p>
Simplex Transmission	Transmission in one direction only.
Half-Duplex	Bi-directional transmission, but only one way at a time. This type of transmission is common in low-cost, medium-speed communication links.
Full-Duplex	Simultaneous communication in both directions.
Asynchronous Transmission	Transmission without a separate clock. Extra bits delineate the beginning and end of the character. The data rate parity type and word length must be pre-determined.
Synchronous Transmission	Transmission with a separate clock. No extra bits required to establish bit synchronization between sending and receiving devices.
RS-232-C	<p>The Electronic Industries Association (EIA) specification for the "Interface Between Data Terminal Equipment And Data Communication Equipment Employing Serial Binary Data Interchange". This specification is called the RS-232-C standard and it prescribes the electrical characteristics of the signal and the type of connector (plus pin assignments) to be used. A 25-pin connector is specified with each pin designated for a specific signal.</p> <p><u>It does not</u> spell out the code used in the transmission.</p>

IEEE 488 (also GPIB and HP-IB)

The IEEE 488 Standard specifies a general purpose instrument bus.

It is a parallel-bit interface consisting of 8 data lines, 3 handshake lines and 5 management lines.

The bus supports up to 15 instruments, which must include a controller, a talker and a listener. There may be multiples of each but only one controller and one talker can be active simultaneously. A single instrument can be all three types. The instruments are under address control.

The standard connector is a special 24-pin stackable connector.

APPENDIX B

B.0 INTERFACING SERIAL ASCII (RS-232-C)

B.1 GENERAL

The RS-232-C interface is well-defined in terms of signal voltage levels, but poorly defined in terms of signal functions. The applications are so diverse and the manufacturers of compatible equipment so varied, that it is difficult to predict the interface requirements. In order to minimize the problem, this appendix supplements the serial ASCII information in the body of the manual to provide a better understanding of the interface requirements. It describes the serial ASCII signal in detail and explains the related parameters. A table provides the popular signal names for all 25 pins of the standard RS-232-C connector. The basic interconnections to the printer are described together with a systematic approach to the interface problem. Once the interface is complete and the Printer is printing data, an occasional missing character might be detected under special circumstances. The probable cause for this is described. Appendix B concludes with an example of a program for the TRS-80-III with the RS-232-C interface option installed that will provide RS-232-C data to the Printer.

B.2 THE RS-232-C SIGNAL

B.2.1 Description

In the Serial ASCII mode, the bit-serial data information is transmitted by the Sending Device and received by the Model 821 Printer on a signal line and a ground reference line. The signal is bipolar with a positive threshold of +3 V and a negative threshold of -3 V. A positive voltage between +5 V and +25 V represents a logic 0 and a negative voltage between -5 V and -25 V represents a logic 1. This is negative-true logic, but it applies only to the data lines. Signals meeting these requirements will be received properly by the Model 821. Handshake signals transmitted by the Model 821 are nominally +10 V and -10 V. Handshake signals received by the Printer must meet the same requirements as the data. However, all handshake signals consist of positive-true logic when considering EIA signal names. A positive voltage represents a logic 1 and a negative voltage a logic 0.

Each character is transmitted as a bit stream representing the ASCII code for that character. The waveform is transmitted least-significant-bit first and the Received Data line idles in the 1 state (negative level).

To indicate the beginning of a character being transmitted, a start bit consisting of a logic 0 (positive level) is always sent first. Following that, the data bits are sent in order from the least significant bit (LSB) to the most significant bit (MSB). Each bit remains on the Received Data line for exactly one bit time. The bit time is the period associated with the bit rate

(baud). The Printer times the incoming signal and samples the state of the Received Data line as closely as it can to the center of the bit periods. Both the Sending Device and the Printer must agree on the length of time each bit will be held on the line or the transmission will be garbled by samplings taken at the wrong times.

If a noise pulse should occur at the sample time, it is possible that the bit in the transmission could be misread. So, following the transmitted data bits, there may be a parity bit which is used for error detection.

If the Sending Device keeps track of the number of 1's in the character being sent, it can set the parity bit (either a 1 or 0) so that the total number of 1's sent is either even (even parity) or odd (odd parity). Similarly, the Printer can keep track of the 1's received and so determine whether the transmission was received without error. If a parity error is detected by the Model 821 Printer, a question mark is printed for that character.

The last bits to be transmitted are the stop bits. These bits do not carry information but allow the Printer to prepare for the next character. There may be one, one-and-a-half or two stop bits.

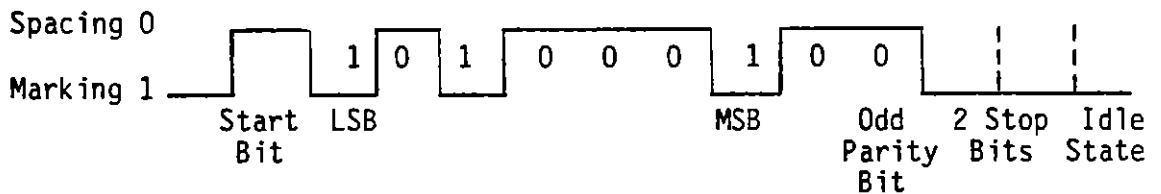

ASCII Letter E (1000101)

NOTE: For the 8-bit word-length above, a dummy zero is added to the 7-bit ASCII character. It would not be present if a 7-bit word format was being transmitted.

The Start bit for the next character may or may not start at the end of the previous Stop bit. The signal could idle at a low level waiting for the handshake signal representing a buffer full condition (see 4.2) to go false before transmitting the next character.

B.2.2 Signal Format Variations

The signal used in RS-232-C bit-serial transmission may vary depending on certain parameters. It is necessary that the transmitting and receiving devices are in agreement on these parameters for proper communication. These parameters are baud (bit rate), word length, parity and number of stop bits.

B.2.2.1 Baud (Bit Rate) - The baud is the bits/second rate of the signal. The standard bauds are 50, 75, 110, 134.5, 150, 300, 600, 1200, 1800, 2400, 3600, 4800 and 9600 bits/second. Of these, the Model 821 Printer provides a choice of the following bauds:

110, 150, 300, 600, 1200, 2400

At bauds over 150 it is necessary to use handshaking to prevent the transmission of data at an average rate exceeding the print-rate capability of the Printer. A 41-character input buffer allows the Printer to be receiving data while it is printing.

B.2.2.2 Word Length - The word length is the number of data bits between the Start bit and the Parity bit. If there is no Parity bit, it is the number of bits between the Start bit and the Stop bit. The Model 821 provides a choice of the following 3 word lengths:

6,7,8

The ASCII code used by the Printer is basically a 7-bit code (96 printable characters + 32 control characters). If an 8-bit word is used, the eighth bit appears after the MSB position and is ignored.

If a 6-bit word is used, a subset of the 96 printable characters is selected. This subset includes the numbers, symbols and upper case letters and excludes the lower case letters. It is the middle four of the eight columns shown in the ASCII code chart in Figure 3.1 on page 10.

B.2.2.3 Parity - The parity bit may be added, by the Sending Device, to each character to produce either an even number of 1-bits (even parity) or an odd number of 1-bits (odd parity). The Sending Device could also leave out the parity bit (no parity). The Model 821 therefore provides the following parity choice:

Even, Odd, None

If either even or odd parity is selected by both the Sending Device and the Printer and the parity check made by the Printer fails, a question mark is printed.

B.2.2.4 Stop Bits - The Sending Device may send either 1, 1 1/2 or 2 Stop bits. No switch positions are provided on the Printer to select one of the above. The Printer checks only for the first stop bit. If it should be missing, the character is ignored.

B.3 EIA STANDARD PIN ASSIGNMENTS

The EIA specification defines the electrical characteristics for an interface between some form of Data Terminal Equipment (DTE) and some form of Data Communications Equipment (DCE) or modem. The pin assignments and signal names are given in Table B-1 for reference purposes only.

PIN NUMBER	CIRCUIT NAME	DESCRIPTION
1	AA	PROTECTIVE GROUND. Electrical equipment frame ground. Also may be ac power ground.
2	BA	TRANSMITTED DATA. Data from terminal to data communications equipment (modem).
3	BB	RECEIVED DATA. Data from modem to terminal.
4	CA	REQUEST TO SEND (RTS). Indicates to sending modem that terminal is ready to transmit.
5	CB	CLEAR TO SEND (CTS). Indicates to terminal that modem is ready to transmit.
6	CC	DATASET READY (DSR). Indicates to terminal that modem is connected to a communications channel and not in a test or loopback mode.
7	AB	SIGNAL GROUND. The common ground reference potential for all circuits except protective ground.
8	CF	RECEIVED LINE SIGNAL DETECTOR (LSD). Indicates to terminal that receiving modem is receiving carrier from remote transmitting modem.
9	(+V)	(RESERVED FOR DATASET TESTING). Often has positive (+12 V) voltage available for testing.
10	(-V)	(RESERVED FOR DATASET TESTING). Often has negative (-12 V) voltage available for testing.
11	—	UNASSIGNED.
12	SCF	SECONDARY RECEIVED LINE SIGNAL DETECTOR. Indicates to terminal that receiving modem is receiving secondary carrier signals from remote transmitting modem.
13	SCB	SECONDARY CLEAR TO SEND. Indicates to terminal that local modem is ready to transmit signals over secondary channel.
14	SBA	SECONDARY TRANSMITTED DATA. Equivalent of transmitted data circuit on pin 2 except that it is used to transmit data over the secondary channel.
15	DB	TRANSMISSION SIGNAL ELEMENT TIMING. Signal from modem to terminal transmitter interface to provide signal element timing.
16	SBB	SECONDARY RECEIVED DATA. Equivalent to received data circuit on pin 3 except that it is used for receiving data from the secondary channel.
17	DD	RECEIVER SIGNAL ELEMENT TIMING. Signal from modem to terminal receiver interface to provide signal element timing.
18	—	UNASSIGNED.
19	SCA	SECONDARY REQUEST TO SEND. Indicates to modem that sending terminal is ready to transmit data over the secondary channel.
20	CD	DATA TERMINAL READY (DTR). Signal from terminal to modem indicating that terminal is ready to receive and transmit data.
21	CS	SIGNAL QUALITY DETECTOR. Signal from modem indicating whether or not there is a predefined high probability of error in received data.
22	CE	RING INDICATOR (RI). Signal from modem indicating that a ringing signal is being detected over the line.
23	CH/CI	DATA SIGNAL RATE SELECTOR. Selects between the two data rates for dual-rate modems.
24	DA	TRANSMIT SIGNAL ELEMENT TIMING. Transmit clock supplied by terminal to modem.

EIA Standard Pin Assignments

Table B-1

B.4 PRINTER INTERFACE

The EIA Standard uses three wires for actual data communication and many more for various types of control. Confusion arises in many applications such as a computer communicating with a printer. Which is the DTE and which is the DCE? This will be defined below for the Model 821 Printer.

B.4.1 Data Wires

There are three data wires:

- (1) Transmitted Data
- (2) Received Data
- (3) Signal Return

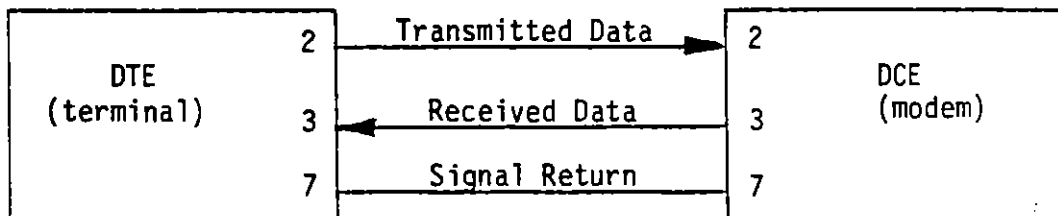

RS-232-C Standard

It can be seen that the pin connections depend on whether a device is a DTE or DCE. If it is a DTE, data is received on Pin 3, but if it is a DCE, data is received on Pin 2.

Considering only the pin connections, the Model 821 is wired as a DTE terminal. Data is received on Pin 3 but since the Model 821 printer does not transmit data, Pin 2 is not connected.

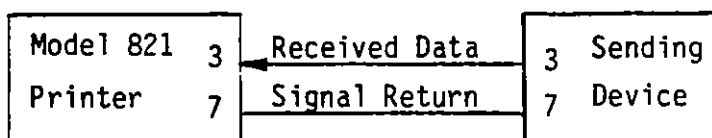

If the Sending Device was designed as a DTE, it would probably transmit data on Pin 2. This would require either a crossover in the cable (Pin 2 of the Sending Device to Pin 3 of the Printer), the use of a Serial Interface Adapter (see Appendix C) or the addition of jumper W5 and deletion of jumper W4 on the main Printer board to activate the ALTERNATE INPUT, Pin 2.

B.4.2 Control Wires

The EIA standard defines a large number of control wires for use between a DTE and a DCE. However, in the strict RS-232-C definition, none of the functions meet the handshake requirements between the Printer and a Sending Device. The purpose of the handshake mechanism is to prevent the Sending Device from transmitting data faster than the Printer can use it. Different manufacturers use different control lines as handshake lines. The Model 821 Printer uses the following three control lines:

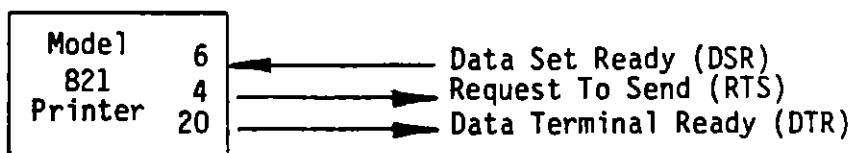

Pin 6 - Data Set Ready (DSR)

This line serves as a select or enable signal. When this input is open or high, this printer is enabled to receive data. When it is grounded or low, the printer is disabled and any data on the signal lines is ignored.

Pin 20 - Data Terminal Ready (DTR)

This line provides a handshake signal that indicates a buffer-full condition when it is low false (-10 V). The Sending Device should finish sending the character in process but should not send any new characters until the DTR goes high true (+10 V). The latter will occur when the Printer has finished printing a line, releasing the corresponding buffer space.

Pin 4 - Request to send (RTS)

This line is identical to the DTR line (Pin 20) described above when DIP switch S6-1 is on, and is open when DIP switch S6-1 is off. It is provided as a convenient interface signal for those Sending Devices that are designed to use the RTS line for handshake control.

B.5 REAR CONNECTOR

The rear connector for receiving ASCII Serial data is a 25 pin, D-subminiature female receptacle. According to the EIA Standard, a DTE "terminal" that receives data on Pin 3 should have a male plug. However, since most printers and CRT's have a female receptacle, the Model 821 Printer was also designed to have a female receptacle. The mating connector, therefore, is a male plug.

B.6 INTERFACE PROCEDURE

Due to the many variables and real lack of standardization for RS-232-C serial communication, hardware interfacing must be approached methodically to guarantee success. The following is a suggested approach to the initial set-up.

B.6.1 Hardware Set-Up

- (1) Plug in the interconnecting cable to the Sending Device only and let the Sending Device send out data, preferably at 110 baud. Using an oscilloscope, locate the data signal on the connector that will eventually plug into the printer. It should appear on either Pin 2 or Pin 3 referenced to ground, Pin 7. If it appears on Pin 3 and the connector is a male plug, it will connect properly to the printer. If not, a Serial Interface Adapter Option (Appendix C) or a short adapter cable must be used. If the data signal appears on Pin 2 of the interface cable, it will have to be crosswired to Pin 3. An alternative to crosswiring the adapter cable is to cut jumper W4 and install jumper W5 on the main printer board. This brings the input signal in on Pin 2 instead of Pin 3.

- (2) Before plugging the interface cable into the printer, check the handshake control inputs to the Sending Device to verify proper operation. With the oscilloscope connected to the data signal, connect Pin 20 of the interconnect cable to -10 V. This represents a Buffer Full (false DTR) signal from the printer and the data signal should cease. If it doesn't, try connecting Pin 4 to -10 V. This also represents a Buffer Full condition. If neither of these stops the data signal, try other pins. If success is achieved with another pin, it will have to be cross-wired to Pin 20 of the printer.
- (3) For the following switch set-up, refer to the switch position table in Section 3.6 of the manual. Connect the interface cable to the Model 821 Printer. If Pin 4 in the previous step was the correct handshake line, then turn on DIP switch S6-1 (Enable RTS); otherwise, turn it off. Turn off all other S6 switches until basic communication has been established. Set the Baud of the printer to that of the Sending Device using DIP switches S1-1, S1-2, and S1-3.

Set Parity to that of the Sending Device using S1-4 and S1-5. Turn off S1-6, S1-7 and S1-8 until basic communication has been established.

Turn on S5-4, the Serial print mode.

Set the Word Length of the printer to that of the Sending Device using DIP switches S5-7 and S5-8. Turn off switches S5-1, S5-2, S5-3, S5-5 and S5-6 until basic communication has been established.

- (4) Plug-in the printer and push the Reset button so the printer will read and store the switch settings. If the Sending Device, which should be in the half-duplex mode, is sending data, the printer should now be printing. If the printer is not printing, check the handshake and data signal lines with the interconnect cable in place.
- (5) Once basic communication is established, the remaining switch positions can be set to meet the exact requirements of the interface.

B.6.2 Handshake Set-Up

The EIA Standard does not apply to handshaking between a DTE and a DCE on a character-by-character basis. The DTE asserts (ie. sets to 1) the Request-to-Send (RTS) line when it has data to transmit and then waits for the DCE to assert the Clear-to-Send line before transmitting. These signals were intended as a system handshake between a terminal and modem, to allow the terminal to request control of the communications link from the modem and to let the modem tell the terminal when control has been acquired.

Some manufacturers of Sending Devices ignore this strict definition by using either Data Terminal Ready (DTR), Data Set Ready (DSR), Request to Send (RTS) or Clear to Send (CTS) as handshake lines.

As described in section 4.2, the Model 821 uses the following control signals:

- | | |
|-------------------------------------|---|
| Data Set Ready (DSR)
Pin 6 | - Select or enable input. High to enable receipt of data for printing. |
| Data Terminal Ready (DTR)
Pin 20 | - Buffer-full output to the Sending Device to inhibit the sending of any new characters while this line is low. |
| Request to Send (RTS)
Pin 4 | - Same as DTR. This line can be opened by turning off DIP switch S6-1 if the DTR line is used by the Sending Device as a handshake. |

B.7 MISSING CHARACTERS

Under certain circumstances, it may be discovered that the Printer is not printing all of the characters transmitted by the Sending Device and the printout will contain missing characters. There are several possible causes for this problem.

- (1) Since the Sending Device can usually send characters at a higher rate than the Printer can print them, the only way to slow down the transmission of characters is with the Buffer Full handshake signal (DSR on Pin 20 or RTS on Pin 4 when S6-1 is on). If the Sending Device is not recognizing the Buffer Full signal properly, it will continue to send characters after the buffer is full and these characters will be lost and will be missing in the printout.

The printer can receive characters without handshaking at either 110 or 150 baud rates. It is suggested that the initial setup be made at one of these rates. There should be no missing characters if the characters sent are all printable characters, ie. no control characters (see (3) below). Once this is working properly, then higher baud rates with handshaking can be attempted. If characters are missing at the higher baud rates, it is possible the Sending Device is not recognizing the handshake signal.

- (2) Another possible cause for missing characters is associated with the timing of the Buffer Full handshake signal. It may be received properly by the Sending Device but the response of the Sending Device may not be fast enough to prevent the following character from being transmitted and lost in the printer due to a buffer-full condition.

The Buffer Full signal from the printer goes true at the center of the Start pulse of the last character being received for which there is buffer space available. The Sending Device should complete the transmission of this character but send no more characters until the Buffer Full signal goes false.

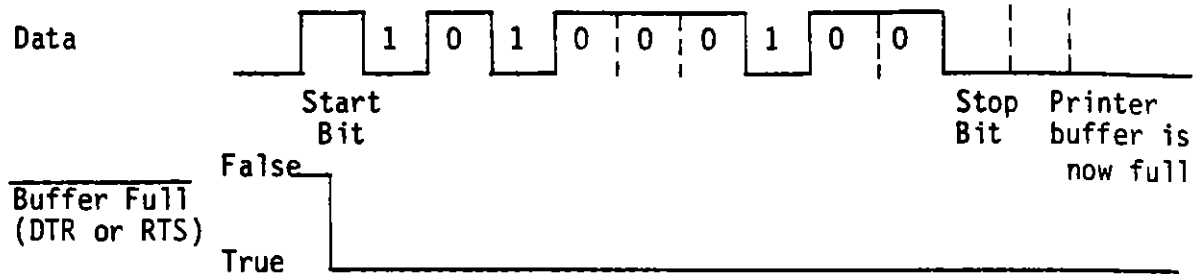

The Sending Device has a minimum of 7 1/2 bit periods (1/2 Start bit, word length = 6 bits, no parity, 1 stop bit) to react to the Buffer Full signal and halt the transmission of the next character. Normally this is not a problem for a computer or microprocessor that is generating the data signal directly. However, the Sending Device may contain a UART (Universal Asynchronous Receiver Transmitter) which is an LSI microcircuit manufactured by several different companies. This device generates the bit-serial data signal from a bit-parallel input and contains an internal one-character buffer that receives a new bit-parallel character as the bit-serial transmission of the previous character begins.

The problem encountered when the Sending Device uses a UART is that the printer issues a Buffer Full signal at the middle of the Start bit of the last character that it can accept and the UART has already accepted the next character into its internal one-character buffer. When it receives the Buffer Full signal, the Sending Device doesn't put any more characters into the UART but the last one that was put into its internal buffer is transmitted and is one more than the printer buffer can accept, so that character is lost.

The solution to this problem is to put a delay in the Sending Device software or hardware that delays the introduction of the next character into the UART. If this delay is slightly over 1/2 bit-period from the beginning of the serial-bit transmission of the present character, then a true Buffer Full signal can be detected before the next character is added to the UART buffer.

Since there is some fixed delay already in the UART and the Sending Device software and/or hardware, it is possible that no problem will be encountered at the higher baud rates. The 1/2 bit-period at these rates might be less than the fixed delay.

- (3) When a TRS-80 personal computer, with an RS-232-C option board installed, was used as a Sending Device to send characters to the printer, no problem was encountered at any rate provided the characters were all printable characters, ie. no control characters. This was because at rates of 300 baud and higher, the fixed delay was greater than 1/2 bit-period and at rates of 110 and

150 baud, the printer was fast enough that the buffer never filled. Remember that the printer can print at 110 and 150 baud without handshaking.

However, a problem was encountered when the Sending Device sent a large number of non-printable control characters in addition to the printable characters. These non-printable control characters filled the buffer without the release of buffer space obtained when a line is printed. Therefore, when the buffer filled at 110 and 150 baud rates, missing characters resulted from the problem outlined in (2) above. The solution was to put a delay routine in the TRS-80 software program to insure that a Buffer Full signal was detected before adding the next character to the UART on the RS-232-C interface board. At baud rates of 300 and higher, the delay routine in the software program was not required.

When the statement is made that the Model 821 printer can print at 110 and 150 baud rates without handshaking, it must be qualified in two respects. First, non-printable control characters can fill the buffer without any release of buffer space obtained when a line is printed. This could cause missing characters.

Second, certain control characters such as carriage return, line feed and vertical tab cause the printer to print a line of characters or advance the paper one or two print-lines. This takes 1/2 to 1 seconds during which time more characters are being received by the buffer. If short lines are being printed (reduced buffer space being released each 1/2 second) or a number of control characters that advance the paper are introduced, it is possible for the buffer to fill and handshaking would be required to prevent missing characters.

B.8 TRS-80 APPLICATION PROGRAM

The following is a software program for the Radio shack TRS-80-III computer with RS-232-C interface option. This program may be used to provide data to the Model 821 Printer. It illustrates the use of a delay routine for preventing missing characters when operating at rates of 110 or 150 baud.

```

50 REM  PROG NAME IS 'SERIAL TRANSMIT' - <BRLXMIT1>   FVG 1/82
60 CLEAR 1000
70 DEFINT A-Z:CLS
73 REM
75 ' * * * * * ENTER BAUD RATE * * * * *
78 REM
80 INPUT "ENTER BAUD RATE  110 150 300 600 1200 2400  -";B#: A=VAL(B#) : B
=A
90 IF B=110 THEN B=2 ELSE IF B=150 THEN B=4 ELSE IF B=300 THEN B=5 ELSE IF B=600
# THEN B=6 ELSE IF B=1200 THEN B=7 ELSE IF B=2400 THEN B=10 ELSE GOTO 50
100 POKE 16880, (B*16)+B ' TRANSMIT/RECEIVE BAUD CODE LOCATION
103 REM
105 ' * * * * * ENTER REMAINING RS-232C PARAMETERS * * * * *
108 REM
110 INPUT"ENTER PARITY ON/OFF  0=ENABLED / 1=DISABLED  -";D : IF D=1 THEN P#="
NONE"ELSE IF D>1 THEN GOTO 110
120 IF D=1 THEN140
130 INPUT"ENTER PARITY TYPE  0=ODD / 1=EVEN  -";P : IF P=1 THEN P#="EVEN"EL
LSE IF P=0THEN P#="ODD"ELSE GOTO 130
140 INPUT"ENTER WORD LENGTH  5 6 7 8  BIT'S  -";W# : W=VAL(W#)-5
150 INPUT"SELECT STOP BITS  1 stop bit / 2 stop bits  -";S :S=S-1 : IF S=0 THEN
S#="1 STOP BIT"ELSE IF S=1 THEN S#="2 STOP BITS" ELSE GOTO 150
155 REM  PRTY TYPE + WORD + STOPS +PRTY SLCT+XMIT+DTR+RTS
160 POKE 16889, ((P*128)+(W*32)+(S*16)+(D*8)+(1*4)+(1*2)+(1*1))
170 INPUT"ENTER HANDSHAKE MODE  0=OFF / 1=ON  -";H:IF H=0 THEN H#="HANDSHAKE OF
F"ELSE IF H=1 THEN H#="HANDSHAKE ON"ELSE 170
175 INPUT"ENTER DELAY (0 TO 100)  ";D#: D=VAL(D#)
180 REM
185 ' * * * * * PLACE UART IN WAIT MODE * * * * *
190 REM
200 POKE 16890,1          WAIT MODE
203 REM
205 ' * * * * * DEFINE USER ROUTINES FOR PARAMETER INITIALIZATION * * *
210 DEFUSR0 = &H005A
220 X=USR0(0)              'INITIALIZE RS-232C
230 DEFUSR2 = &H0055
240 CD = 16880            'LOCATION OF CHARACTER OUTPUT BUFFER
250 REM
300 ' * * * * * BEGIN MAIN PROGRAM * * * * *
310 REM
315 PRINT " "
320 PRINT"ENTER DATA TO TRANSMIT - THEN PRESS <ENTER>"
330 INPUT L#
340 PRINT " "
350 GOSUB 500              'TRANSMIT DATA SUBROUTINE
400 GOTO 330              'RETURN TO MAIN PROGRAM FOR MORE DATA
490 REM
500 ' * * * * * SEND LINE OF TEXT SUBROUTINE * * * * *
505 REM
510 FOR L=1 TO LEN(L#)+1   ' FIND TOTAL LENGTH OF STRING
520 C#=MID$(L#,L,1)       'SELECT CHARACTER TO SEND
530 IF C#="" THEN X=13 ELSE X=ASC(C#) 'CHECK FOR END OF STRING
550 IF H=0 THEN GOTO 570  'NO HANDSHAKE
560 IF INP(232)<>127 THEN GOTO 560 'HANDSHAKING
570 POKE CD,X             ' PLACE CHARACTER IN SENDING REGISTER
580 X=USR2(0)            'INTERNAL SUBROUTINE TO XMIT CHARACTER
583 FOR X=1 TO D : NEXT X ' DELAY ROUTINE (FOR LOW BAUD RATES)
585 NEXT L               ' GET NEXT CHARACTER IN STRING TO SEND
590 RETURN              ' * * * * * RETURN TO MAIN PROGRAM * * * * *
600 END

```

C.0 SERIAL INTERFACE ADAPTER

C.1 GENERAL

The Serial Interface Adapter (SIA) is a small printed circuit board, with RS-232-C 25 pin D-subminiature connectors on either end, that is inserted between the Model 821 Printer and the cable from the Sending Device (Figure C.1). This is an optional device that aids in the successful mating of the Sending Device to the Printer. Since the data, handshake and enable signals may appear on various lines of the Sending Device Cable, this board provides a means for locating the correct lines and cross-connecting them (if necessary) without rewiring the connector.

The SIA contains 6 posts (J1A) connected to pins 2, 3, 4, 6, 10 and 20 of the Printer connector and 9 posts (J2A) connected to pins 2, 3, 4, 5, 6, 8, 18, 20 and 25 of the Sending Device cable connector. These pins were selected to include the lines most likely to be used for the three key signals of data, handshake and enable. However, access is available to all 25 pins of the cable connector by means of printed-through holes (J2B). Jumpers are used to connect the three key signals between the Printer and the Sending Device since none of the lines go between the outside connectors J1 and J2 except for the ground line (pin 7 on both connectors).

The presence of a signal and its polarity is displayed by two LED's. A jumper from the TEST post to a post under investigation will cause the red LED to light if a positive signal is present and the green LED to light if a negative signal is present. If the signal is alternating between both polarities, both LED's will light and if there is no signal (ground level) then neither LED will light.

This procedure is written specifically for the RS-232-C interface. A similar procedure can be followed for the TTL interface type by remembering that the signal never goes negative (the green LED will not light) and the TTL input to the Printer is applied to pin 12 instead of pin 3 of P1. The connection to Pin 12 has to be soldered.

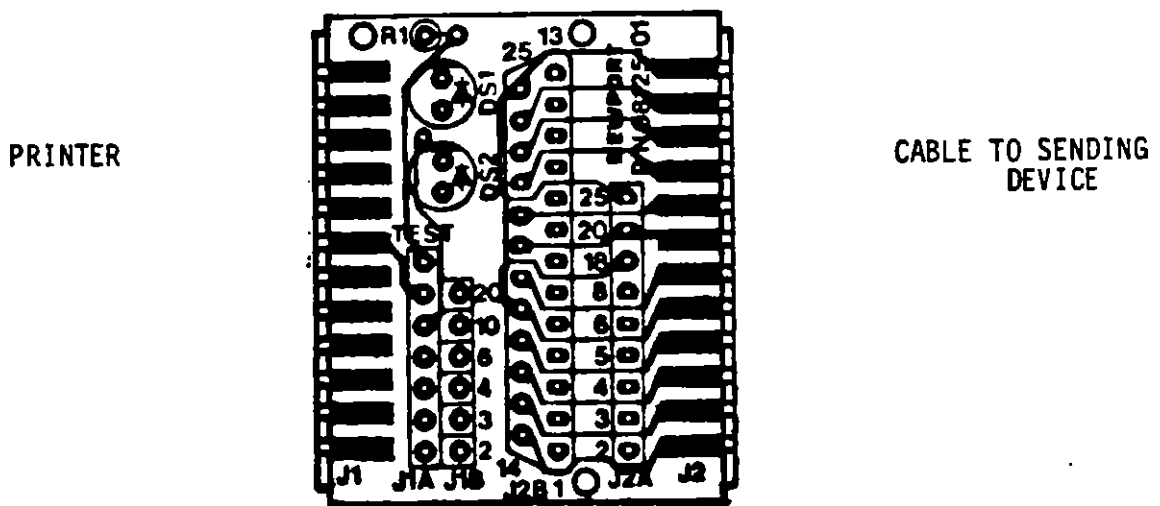

Figure C.1

C.2 PROCEDURE

- (1) Plug connector J1 of the Serial Interface Adapter (SIA) into connector P1 of the Model 821 Thermal Printer. Plug the connector on the end of the Sending Device cable into J2 of the SIA. Start with all jumpers removed from the SIA.
- (2) Determine which pin of the Sending Device Cable connector carries the data signal. It should be either pin 2 or pin 3.
 - (a) Turn on the Sending Device and have it send data continuously. It should be in the half-duplex mode and set to the lowest baud rate possible for easiest detection.
 - (b) Connect a jumper from the TEST post to the pin 2 post of J2A (Sending Device). If the RS-232-C data signal is on that pin, the red and green LED's will flash. If they don't flash, connect the jumper from TEST to the pin 3 post of J2A. They should now flash (or light continuously for higher baud rates).

Leave this jumper in place so the data signal will cause the LED's to indicate continuously.
- (3) Determine which pin of the Sending Device Cable connector should receive the handshake (BUFFER FULL) signal from the Printer. This is a signal that inhibits data from being transmitted while it is at a negative level.
 - (a) Connect one end of a jumper to the pin 10 post of J1A (Printer). This jumper will have -10 V from the Printer on it. Connect the other end to the pin 4, 5, 8, 6, 20 posts of J2A (Sending Device) in that order while observing the LED indication of the input signal. Stop when the red LED extinguishes, indicating loss of input signal.
 - (b) Remove the end of the jumper connected to the pin 10 post of J1A and connect it to the pin 20 post of J1A, which is the BUFFER FULL output of the Printer.
- (4) Determine which pin of the Sending Device Cable connector carries the enable (Data Set Ready) signal.
 - (a) Remove the end of the jumper from the TEST post and connect it to the pin 3 post of J1A (Receive Data).
 - (b) Connect a jumper from the TEST post to the pin 4, 5, 6, 8, 20 posts of J2A (one at a time) that were not selected in step 3a above. Stop on the pin that lights the red LED (positive signal level). Disconnect the end of the jumper from the TEST post and connect it to the pin 6 post of J1A (Data Set Ready).
 - (c) This completes the interfacing. Set the bit rate of the sending device to the desired baud.

- (5) Set the Printer DIP switches by performing the Serial ASCII Setup according to the instructions in Section 3.8 of the manual.
- (6) Check the interface for correct operation by sending data and observing the printout. Once it is functioning properly, there are three alternatives.
 - (a) The SIA can be left with the jumpers in place.
 - (b) The jumpers can be replaced by hard-wiring between J1B (Printer) and J2B (Sending Device) using the same pin numbers as the jumpers.
 - (c) The SIA board can be removed and the required changes to the pin numbers can be made by re-wiring the Sending Device Cable connector.