



INSTRUCTION  
MANUAL

**pH/ORP RECORDER / CONTROLLER**

MODELS:

PRC-212

PRC-212-ORP

PRCD-212

PRCD-212-ORP

## TABLE OF CONTENTS

ABOUT THIS MANUAL	Page 1
I. INTRODUCTION	1-2
II. UNDERSTANDING THE PRC-212 FUNCTIONS	2
III. FEATURES	2-3
IV. OPTIONS	3
V. SPECIAL CONSIDERATIONS - pH	3-5
VI. INSTALLATION	5-8
VII. CALIBRATION	8-11
VIII. CHART RECORDER PAPER INSTALLATION	11-12
IX. OPERATION	13-15
X. STEP-BY-STEP OPERATION INSTRUCTIONS	15
XI. TROUBLE SHOOTING	16A-D
XII. WARRANTY	17
DRAWING A-190	18
DRAWING A-195	19
DRAWING A-187	20
DRAWING 20002-A	21
DRAWING 20004-A	22
FIXED RESISTOR VALUE VS TEMPERATURE	23
SCHEMATIC	24

## ABOUT THIS MANUAL

This manual introduces you to Presto-Tek's 212 series pH/orp recorder, controllers and monitors. Use it to understand how your model works, what its functions are, and how to easily install and maintain your pH/orp system. This manual tells you:

- About the 212 series in general
- Specific features, functions and options about the model you have chosen
- Special consideration prior to installation of a pH/ORP system
- Step-by-step installation
- Step-by-step calibration
- Chart paper replacement
- Operation
- Trouble shooting
- Warranty information

## I INTRODUCTION

You have just received the PRC-212, a member of our new 212 family of instruments designed to monitor, record and control levels of pH and oxidation reduction potential. If you have used traditional pH and ORP instrumentation, you will quickly appreciate the ease with which your PRC-212 is installed, calibrated and serviced.

If this is the first system you have installed, this manual provides an easy to follow step-by-step procedure to ensure correct installation and proper operation.

If you are familiar with pH and ORP installations, read Section III to familiarize yourself with 212 series features and functions prior to installation. This section

thoroughly describes these functions and shows their physical location on the instrument itself.

## II

### UNDERSTANDING THE PRC-212'S FUNCTIONS

The PRC-212 is really two instruments: A pH(ORP) recorder and a pH(ORP) controller. It accepts as its input a single pH or ORP electrode. This input is digitally displayed and continuously recorded via the strip chart recorder. If you chose the model PRCD-212, your recorder and controller utilize two independent electrode inputs.

Two set points are provided. These set points serve as alarm trips which actuate 6AMP solid state relays when they are exceeded. They may be set to actuate when the pH(ORP) is ascending or descending. The set points may be arranged to control in either of the following configurations: High-Low, High-Higher, Low-Lower, or only one set point may be used. Typically, small chemical metering pumps are used for acid and caustic addition. (See specifications regarding pump sizes.)

The strip chart recorder continuously records the input from the pH(ORP) electrode. The pH scale is 2 to 12 with each large division being one pH unit. The ORP scale is 0 to +1000 mV with each large division being 100 mV.

The chart speed is normally 1" per hour. At this speed, one roll of chart paper will last approximately 30 days. The sliding door on the recorder allows the date and time to be marked.

## III

### FEATURES

The PRC-212 has many standard features including:  
(See Drawing A-190)

- Compact design
- Front panel control
- Hinged fold down panels for convenient wiring and electrode connecting
- Adjustable deadband

- Red LED indicator lights acknowledge when set points are exceeded
- 3-1/2 digit 1/2" high LCD display
- Push button digit switches take the guesswork out of pH(ORP) set point adjustments

#### IV OPTIONS

Some options you may have chosen include:

- Remote mounting of pHTM module for applications where electrode is located more than 10 feet from the controller
- Time delay control option which overrides set points when pH(ORP) is not adjusted within predetermined time period
- Benchtop or NEMA 4X enclosure
  - Δ The benchtop enclosure is particularly useful when the PRC-212 will be moved from one place to another. Plug-in power and electrode connections are located on the back panel.
  - Δ The NEMA 4X enclosure is rated for wet corrosive environments. It is easily wall mounted, has a clear lexan cover and a locking hasp.

#### V SPECIAL CONSIDERATIONS PH

The pH electrode is the most sensitive and crucial portion of your system as the PRC-212 relies on a correct input from the electrode. Proper adjustment and a correct record are completely dependent on the measurement reliability of the pH electrode. Some important factors to consider are:

- ELECTRODE LOCATION - The pH electrode should always be mounted in a vertical position in a location near but down stream from where the reagent will be added. This location should be

representative of the whole process solution. The electrode must remain wet at all times. (Ensure proper mixing of the process solution.)

- MAINTENANCE - To ensure the validity of the pH input, the electrode must be cleaned and calibrated periodically. In every application the pH electrode may become coated with the process residue. Consult the electrode manufacturers recommendations for cleaning, or contact Presto-Tek for recommendations. Each time the electrode is cleaned or replaced, it must be recalibrated to the PRC-212. Make sure that a regularly scheduled maintenance program is enacted. Your particular application will determine the frequency with which the electrode should be checked.
- THIS GLASS may also be attacked by high alkaline solutions (particularly at high temperatures) which damage the glass or cause sodium ion error. Very acidic solutions which contain flourides may dissolve the glass membrane. Special electrodes are available. Consult the factory for details.
- TEMPERATURE also affects the pH measurement. The PRC-212 has automatic temperature compensation capabilities, but an ATC element must also be inserted in the process stream. The 212 series uses a 1000 ohm platinum resistance device as its ATC and it may be mounted in the pH electrode or in its own separate housing.
- TEMPERATURE not only affects the pH measurment but also the normal life expectancy of the pH electrode. Maximum life is achieved at ambient temperatures although special electrodes are available that are more durable at higher temperatures.
- THE CHEMICAL COMPOSITION of the process solution may not only affect the glass pH

electrode but also the electrode assembly housing. In these cases Kynar® or stainless steel housings may be required.

- STRAY CURRENTS in the solution will cause the pH electrode to report incorrect information to the PRC-212. The output from the pH electrode is only a few millivolts. If stray currents are present, they may be picked up by the pH electrode and transmitted to the PRC-212. It is necessary to eliminate the current either by finding the leakage or by adding an earth ground to the solution. Some pH electrode assemblies may incorporate a solution ground (which can be tied to an external earth ground) to eliminate this problem.
- THE PRC-212 has a two independently adjustable set points. The set points drive 6AMP solid state which requires a 200 mA minimum load in order to actuate. relays. These relays are intended to actuate small chemical metering pumps, solenoid valves, alarm, ect. If larger inductive load devices such as mixers are to be actuated, the PRC-212's relays should be used to drive an external motor starter or other interface devices to the heavy inductive load. Consult factory for details.

## VI INSTALLATION (1) UNPACKING

- After unpacking the PRC-212, remove the 4 panel screws from the 4 panel screws from the front panel.

Remove the panel from the the enclosure and inspect for possible shipping damage.

## (2) MOUNTING

- Panel mount enclosure (see Drawing A195, Attachment for panel cut-out dimensions). The panel mount enclosure has two (2) counter

sunk holes in the front lip of the enclosures back cover. Remove the PRC-212's front panel. Insert the back cover through the cut-out. Fasten it to the panel with 6-12 x 1/2" flathead screws and nuts provided.

- NEMA 4X enclosure -  
The NEMA 4X enclosure can be mounted to any flat surface using the four (4) mounting holes in its base.
- Bench Top -  
The bench top PRC-212 version is designed to move where it's needed. Included is a convenient carrying handle. Power and electrode connections are made on the back panel via plug-in connectors.

### (3) WIRING

The front panels are factory prewired from the terminal strip on the controller circuit board to the switch and fuses. The recorder and pHTM are also prewired unless you have ordered the remote pHTM module (see remote pHTM installation). It is necessary to wire-  
(Drwg. #20002A & A187) (Dual unit Drwg. #20004A)

1. Output to the pumps, alarms, valves, etc.
  2. Output to timer alarm (if applicable)
  3. pH(DRP) electrodes
  4. Temperature electrode (if applicable)
  5. Remote pHTM wiring
  6. Input power
- Pull wires through the holes in the rear of the panel mount box, or through the side of the NEMA 4X enclosure.
  - Make sure the instrument panel is fastened securely using the (4) 6-32 Phillips head screws. Loosen the controller's captive thumb screw in the upper left hand corner of the

controller sub-panel, and hinge the sub-panel all the way down.

- (4) TERMINAL STRIP NUMBERING     Find the terminal strip on the right hand side of the sub-panel. The terminal strip is numbered from right to left as you face it. Terminal #1 is nearest the panel hinge and numbers increase to the left to the top of the panel.
- (5) PUMPS, ALARMS, VALVES, ETC.     Connect pumps, valves, alarms, etc. Use #18 gauge wire or larger. Use black wire for the switched 117V connection and white wire for the return to neutral. The switched 117V power is labeled "N.O. Relay". Set point #1 uses (labeled pump 1) terminals 1 and 2; set point #2 (labeled pump 2) uses terminals 4 and 5. (Terminal strip #'s 3 and 6 are normally closed operation.)
- (6) TIME DELAY ALARM     Connect the time delay alarm next (if applicable). Use #18 gauge wire or larger and connect the black to terminal strip #13 labeled N.O. Relay 3 (far left side of terminal strip). Connect the white wire to #14 labeled neutral for return to neutral. If a remote pHTM-1 is to be installed, skip to #6. Connect the pH or ORP electrode whichever is applicable.
- (7) pH(ORP) ELECTRODES     Locate the BNC connector on top of the sub-panel. Connect the pH electrode to the BNC connector. Dual input unit accept 2 electrodes.
- (8) TEMPERATURE ELECTRODE FOR ATC     The PRC-212 will automatically compensate for temperature variations if a 1000 ohm platinum RTD is connected. If ATC is required, locate the terminal strip next to the BNC connector (labeled with a resistor symbol) on top of the sub-panel. Remove the fixed resistor that is shipped with the instrument. Connect the RTD sensor to the terminal strip. If the temperature of the solution remains within 10 degrees of a point, a fixed resistor may be used in lieu of ATC. See page 23 for RESISTANCE VS. TEMPERATURE CHART.

(9) REMOTE PHTM  
WIRING

- If the pH(ORP) electrode will be mounted more than 10 feet from the PRC-212, a remote PHTM-1 transmitter should be installed. If you have purchased a PRCD, the controller transmitter may be remotely installed. The recorder transmitter must remain internal and be installed within 10 feet of the electrode.

(10) INPUT POWER

- Now connect the 117V line current. Make sure the input power circuit breaker and the front panel ON/OFF switch are off. Use #18 gauge wire or larger. Connect a white wire for neutral to #7, a green wire to #8 for ground, and a black wire 117 VAC to #9. Your PRC-212 is now wired and ready for service.

VII  
CALIBRATION

Now that the 212 is wired, follow the steps below to calibrate the pH or ORP electrode: (Skip to section 2 if calibrating an ORP electrode)

(1) pH

- Close the sub-panel and securely fasten the captive thumb screw.
- Turn the PRC-212 front panel ON/OFF switch to ON.
- Switch the standby switch to "STBY" mode. (This disengages power to pumps during calibration.)
- Remove the protective plastic shipping cap from the pH electrode and rinse with pure water.
- Place the pH electrode and temperature probe (if ATC is required) into a #7 buffer solution.
- Using the CAL potentiometer on the front panel, adjust the display to read 7.00.
- Next, adjust the pH CAL knob on the recorder until the indicator on the recorder also reads 7

- Rinse the pH electrode and temperature probe and immerse in a \*10 or \*4 buffer. Choose a buffer which is close to actual solution to be measured.
- Adjust the slope potentiometer on the panel until the digital display reads the value for the buffer chosen.
- Check to see that the recorder indicator needle also reads the correct buffer value.
- Rinse the pH and temperature electrodes and install in the solution to be measured. Calibration is now complete.

(2) ORP

Your instrument has been precalibrated at the factory with use of a mV calibrator. The "CAL" pot has been adjusted for 0 mV. The "SLOPE" pot has been adjusted at 1000 mV.

- ORP electrodes cannot be calibrated, only tested.
- To test your ORP system, use the following procedure:
  - Δ Close the sub-panel and securely fasten the captive thumb screw.
  - Δ Turn the PRC-212 front panel ON/OFF switch to ON.
  - Δ Switch the standby switch to "STBY" mode (this disengages power to pumps during testing.)
  - Δ Prepare a pH buffer for testing. Use approximately one gram quinhydrone to 250 ml of your electrode buffer. The table on the following page shows the theoretical millivolts to be expected between a platinum ORP electrode and the saturated calomel reference or the 4 molar

silver/silver chloride reference when they are immersed in buffers saturated with quinhydrone. Note that the actual measurements will probably differ in absolute value from these because of a number of factors relating to the chemistry, but the difference values between the various solutions will hold within a few millivolts.

QHQ VS.

<u>PH (25°C)</u>	<u>4M AG/AgCl</u>	<u>Sat. Calomel</u>	<u>Difference</u>
0	+499 mV	+455 mV	---
4.01	+262 mV	+218 mV	237 mV
6.86	+ 93 mV	+ 49 mV	169 mV
9.18	- 44 mV	- 88 mV	137 mV

(3) REMOTE  
PHTM  
CALI-  
BRATION

Remote pHTM calibrations follow the same procedures as pH described above with the exception that the CAL and SLOPE adjustments are located on the pHTM module. (If it not possible to view the PRC-212's display during calibration, a digital voltmeter will be required.)

- Connect the digital voltmeter to the two test points on the pHTM module.
- Make sure the pH electrode and temperature probe (if applicable) are connected.
- Now follow the same standardizing procedures as described above.
- The readings on the digital voltmeter for the various buffers are as follows:

pH  
#10 \_\_\_\_\_  
#7 \_\_\_\_\_  
#4 \_\_\_\_\_

- Once calibrated, place the pH (ORP) electrode back in the #7 buffer and go back to

controller.

- Check to see that the digital display and recorder both indicate 7 pH. Adjust the recorder pH CAL pot if necessary.

VIII  
CHART  
RECORDER  
PAPER  
INSTALLATION

A Warning to 'renew chart' appears on the last three feet of each roll of paper. Do not use partial rolls of paper in re-roll mode. Refer to diagram at left.

- Turn power off before loading chart paper
- Open recorder by loosening thumb screw (1).
- Unlatch paper retaining clips (2).
- Open panel to chassis latch (3) RH side plate.
- Remove supply (4) and take up roller (5). If paper is still attached to supply roller, carefully slide the paper from between the front panel and chart drive. Do not pull the paper backward through the recorder because of the danger of snagging the pointer.
- Insert the supply roller into the new roll of chart paper. The perforated end of the paper is nearest to the roller shoulder.
- Unroll about a foot of paper. Slide the paper between the panel and side plate, sprocket holes first. Keep paper taut and close to the drive drum to prevent snagging the pointer.
- Engage the supply roller shaft in both seating notches (6) and check to be sure that the paper sprocket holes engage the time drum sprockets.
- Slide cardboard sleeve all the way on the take up roller against the disc.
- Butt paper against disc and tape the paper to

the sleeve, printed side out. Wrap a few turns of the paper to be sure paper is started true.

- Continue rolling paper and place roller shaft into notches. (Lower notch LH side).
- Close clips (2), latch (3) and recorder front panel. Tighten thumb screw (1).
- Advance paper with the chart advance wheel (8), to assure that paper moves through the recorder. Set to time.

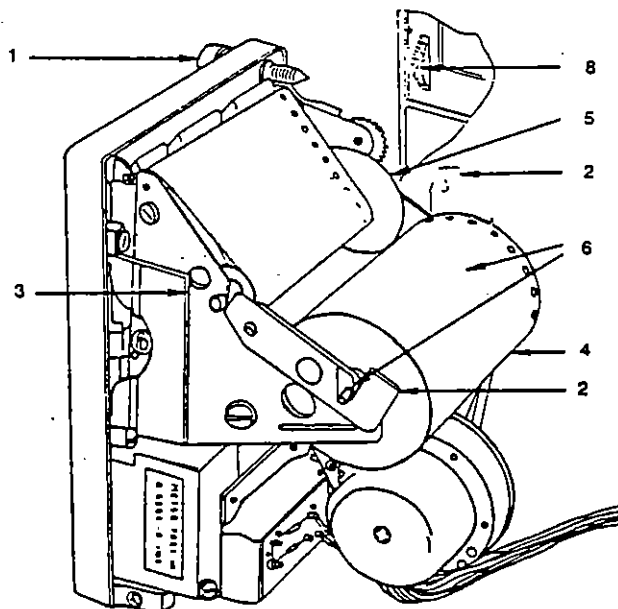

SERIES 200 REROLL

IX  
OPERATION

(1) INDICATORS The PRC-212 has both a digital display and a continuous chart record of the pH (ORP) value.

- Use the digital display for intermittent checks of the pH (ORP) value and during calibration and maintenance.

SCALE

pH.....2 to 12

ORP.....0 to +1000 mV

- Use the chart paper as a permanent record of the pH (ORP) value for any given time period (usually 30 days). The chart recorder travels at 1" per hour. The plastic sliding door may be lowered to mark date and time on the chart paper.

SCALE

pH.....2 to 12

ORP.....0 to 1000 mV

- Use a remote indicator when display of the pH value is required in a control room or office separate from where the PRC-212 is mounted. Two (2) ordinary copper wires may be connected to the small terminal strip mounted on the sub-panel near the panel hinge and directly below the main terminal strip. These wires may be run up to 1,000 feet from the PRC-212 to a loop powered indicator (contact the factory for details).

SCALE

pH.....2 to 12

ORP.....0 to 1000 mV

- SET POINTS - Two independently adjustable set points are provided. They can be set from 2.0 pH (00 in V for ORP) to 11.99 pH (999 mV). The right digit controls .1 pH unit (20 mV). The left

digit controls 1 pH unit (100 mV).

- Each set point can be set to activate either in increasing or decreasing mode. Two A-B switches labeled Pump 1 (for set point #1) and Pump 2 (set point #2) control ascending or descending mode.

Acid feed..... Set switch to A  
Caustic feed..... Set switch to B

For example:

High-Low control: Set Pump 1 to A  
Set Pump 2 to B

High-Higher control: Set Pump 1 to A  
Set Pump 2 to A

Low-Lower: Set Pump 1 to B  
Set Pump 2 to B

- DEADBAND ADJUSTMENT - Adjustment from 1% to 50%, the front panel deadband adjustment allows the operator to control the hysteresis around each set point. This feature allows the system to be fine tuned to the amount of overshoot suitable for the application. For example: Assuming a 1% deadband setting and a set point of 7 pH, the pump will turn on at 7.00 pH and remain on until the pH is adjusted below 6.9 pH. A 5% deadband would keep the pump actuated to 6.5 pH. Use this feature to fine tune the control system as required.
- TIME DELAY - The time delay option, adjustable from 1 to 11 minutes, provides a safety feature in the event that the pH (ORP) system malfunctions. Determine the amount of time necessary to complete deactivation). See the front panel timer. Then, if the pH (ORP) is not

corrected within this predetermined limit, the pumps will be shut down and an output is provided to ring an audio or visual alarm. The system is reset by switching the ON/OFF switch. NOTE: should the time delay not be required, an ON/OFF switch on the top board of the sub-panel disengages this function.

- STANDBY (STBY)/RUN MODE - The Standby/Run mode is provided to disengage power to the pumps and alarms during calibration. Place the front panel toggle switch in the "Stby" mode during calibration and in "RUN" mode during operation.

X  
STEP-BY-STEP  
OPERATING  
INSTRUCTIONS

Now that you understand your PRC-212's functions, follow these procedures to begin normal operations:

- Make sure electrodes are connected
- Turn on power switch
- Set set point #1 to control Pump #1. Set A-B switch for ascending (acid addition) or descending (caustic addition).
- Now set set point #2 similarly (if applicable)
- Adjust deadband for each set point
- Adjust time delay to desired setting or disengage if not to be used
- Switch "STBY" to "RUN" mode and begin normal operation

## TROUBLE SHOOTING GUIDE

SYMPTOM	POSSIBLE CAUSE	SOLUTION
A. No reading on digital display	<ol style="list-style-type: none"> <li>1. No power to unit</li> <li>2. Blown fuse</li> <li>3. Loop wiring open</li> <li>4. Defective transmitter</li> <li>5. Transmitter wires reversed</li> </ol>	<ol style="list-style-type: none"> <li>1. Check input wiring</li> <li>2. Replace fuse</li> <li>3. Check loop wiring between transmitter and display</li> <li>4. Return unit to factory</li> <li>5. Return unit to factory</li> </ol>
B. Reading on display is high or low	<ol style="list-style-type: none"> <li>1. Out of calibration</li> <li>2. Bad probe</li> <li>3. Defective transmitter</li> <li>4. Stray currents</li> </ol>	<ol style="list-style-type: none"> <li>1. Recalibrate</li> <li>2. Change probe</li> <li>3. Replace transmitter or return to factory</li> <li>4. See page 5</li> </ol>
C. Reading on display is negative	<ol style="list-style-type: none"> <li>1. Display out of calibration</li> <li>2. Defective transmitter</li> <li>3. Display wires reversed</li> </ol>	<ol style="list-style-type: none"> <li>1. Return to factory</li> <li>2. Return to factory</li> <li>3. Return to factory</li> </ol>
D. Reading on display is over range	<ol style="list-style-type: none"> <li>1. Display out of calibration</li> <li>2. Defective transmitter</li> </ol>	<ol style="list-style-type: none"> <li>1. Return to factory</li> <li>2. Return to factory</li> </ol>
E. Reading high in 10 buffer or low in 4 buffer	<ol style="list-style-type: none"> <li>1. 100 <math>\Omega</math> temperature sensor instead of 1000 <math>\Omega</math></li> </ol>	<ol style="list-style-type: none"> <li>1. Replace with correct temperature sensor</li> </ol>

## TROUBLE SHOOTING GUIDE

SYMPTOM	POSSIBLE CAUSE	SOLUTION
Unit will not calibrate in buffer solution	<ol style="list-style-type: none"> <li>1. Defective probe</li> <li>2. Protective cap on electrode</li> <li>3. Open temperature sensor or loose wires</li> <li>4. No fixed temperature compensation resistor or loose connection</li> <li>5. Probe not in solution</li> <li>6. Electrode bulb has dried out</li> </ol>	<ol style="list-style-type: none"> <li>1. Replace probe</li> <li>2. Remove cap</li> <li>3. Check wires, replace probe or temperature element</li> <li>4. Tighten connections or install resistor</li> <li>5. Put probe in solution</li> <li>6. Soak probe in 5% HCL for five minutes then soak one to two hours in KCL</li> </ol>
G. Display readings unstable	<ol style="list-style-type: none"> <li>1. Stray currents</li> <li>2. Defective probe</li> <li>3. Defective transmitter</li> <li>4. Temperature sensor open or loose connection</li> <li>5. No fixed temperature compensation resistor or loose connection</li> <li>6. Defective controller</li> </ol>	<ol style="list-style-type: none"> <li>1. See page 5</li> <li>2. Replace probe</li> <li>3. Return to factory</li> <li>4. Check wires, replace probe or temperature element</li> <li>5. Tighten connections or install resistor</li> <li>6. Return to factory</li> </ol>
H. Unit calibrates in buffer solutions, but does not read correctly in process effluent	<ol style="list-style-type: none"> <li>1. Stray currents</li> </ol>	<ol style="list-style-type: none"> <li>1. See page 5</li> </ol>

## TROUBLE SHOOTING GUIDE

SYMPTOM	POSSIBLE CAUSE	SOLUTION
I. Display has extra segments or decimal points	1. Moisture and contaminants on display circuit board  2. Humid or contaminated environment	1. Place unit in dry heat oven at 120° F for 1/2 hour  2. Use Nema 4X enclosure
J. Set point indicators will not turn on	1. Time delay has actuated  2. Standby switch not in "RUN" mode  3. Defective controller	1. Reset time delay by turning front panel power switch off and on  OR Disable time delay with time delay switch  2. Put standby switch in "RUN" mode  3. Return to factory
K. Set point indicators will not turn off	1. Defective controller	1. Return to factory
L. One or both set point indicators operate in the reverse mode	1. A/B switches in wrong position	1. Put switch in correct position
M. One or both relays operate in the reverse mode	1. Load wired to incorrect relay contact	1. Wire to N.O. relay contact
N. Set point indicator turns on but relay does not actuate  OR Set point indicators turn off but relay stays on	1. Defective controller	1. Return to factory

## TROUBLE SHOOTING GUIDE

SYMPTOM	POSSIBLE CAUSE	SOLUTION
O. Relay chatter	1. Noise generated by inductive load  2. Deadband too small  3. Power line fluctuating	1. Required damping network across load, see bottom of page  2. Increase deadband adjustment  3. Provide adequate power for controller
P. Blows fuse when set point actuates	1. Load fuse too small or fuses reversed  2. Load current too high	1. Check fuses  2. Check load

### INDUCTIVE LOADS

The relays in the controllers are rated at 10A at 120 VAC for resistive loads. The rating for inductive loads is 3A with a power factor of .4 at 120 VAC. Inductive loads will cause arcing at the contacts and usually make the contacts fail and the relay remains on all the time. Since this power factor is difficult to determine, it is a good idea to install a damping network across the load to absorb some of inductive effects of the load. The damping network consists of a  $.1 \mu f$  capacitor @ 600V rating in series with a  $1K\Omega$  (2W minimum) resistor. Connect it as shown in the diagram, this will prolong the life of the contacts and reduce electrical noise generated when the contacts open or close.

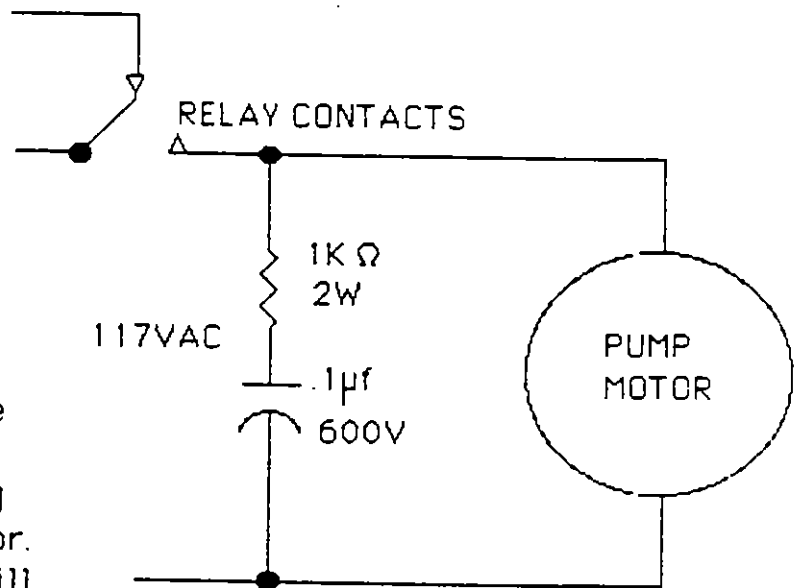

## **WARRANTY**

ALL EQUIPMENT IS FULLY WARRANTED FOR A PERIOD OF ONE YEAR AS TO DEFECTS IN MATERIALS OR WORKMANSHIP. EQUIPMENT RETURNED IS PREPAID TO THE FACTORY. IF, IN THE OPINION OF THE FACTORY, FAILURE WAS DUE TO MATERIALS OR WORKMANSHIP, REPAIR OR REPLACEMENT WILL BE MADE WITHOUT CHARGE AND RETURNED AT NO CHARGE. A NORMAL SERVICE CHARGE WILL BE MADE FOR REPAIRS MADE DUE TO MISTREATMENT, NORMAL WEAR, OR MADE ON EQUIPMENT OUT OF WARRANTY -- IN WHICH CASE, EQUIPMENT IS RETURNED FREIGHT COLLECT.

pH/ORP ELECTRODES CARRY A LIMITED 30 DAY WARRANTY DUE TO THE FRAGILE NATURE OF THIS COMPONENT.

WE ARE GLAD TO OFFER SUGGESTIONS ON THE USE OF OUR VARIOUS PRODUCTS. NEVERTHELESS, THERE ARE NO WARRANTIES GIVEN EXCEPT SUCH EXPRESSED WARRANTIES OFFERED IN CONNECTION WITH THE SALE OF A PARTICULAR PRODUCT. THERE ARE NO IMPLIED WARRANTIES OF MERCHANTABILITY OR OF FITNESS FOR A PARTICULAR PURPOSE GIVEN IN CONNECTION WITH THE SALE OF ANY GOODS. IN NO EVENT SHALL PRESTO-TEK CORPORATION BE LIABLE FOR CONSEQUENTIAL, INCIDENTAL OR SPECIAL DAMAGES. THE BUYER'S SOLE AND EXCLUSIVE REMEDY AND THE LIMIT OF PRESTO-TEK CORPORATION'S LIABILITY FOR ANY LOSS WHATSOEVER, SHALL NOT EXCEED THE PURCHASE PRICE PAID BY THE PURCHASER FOR THE UNIT OR UNITS OR EQUIPMENT TO WHICH A CLAIM IS MADE.

REVISIONS		
LTR	DESCRIPTION	DATE

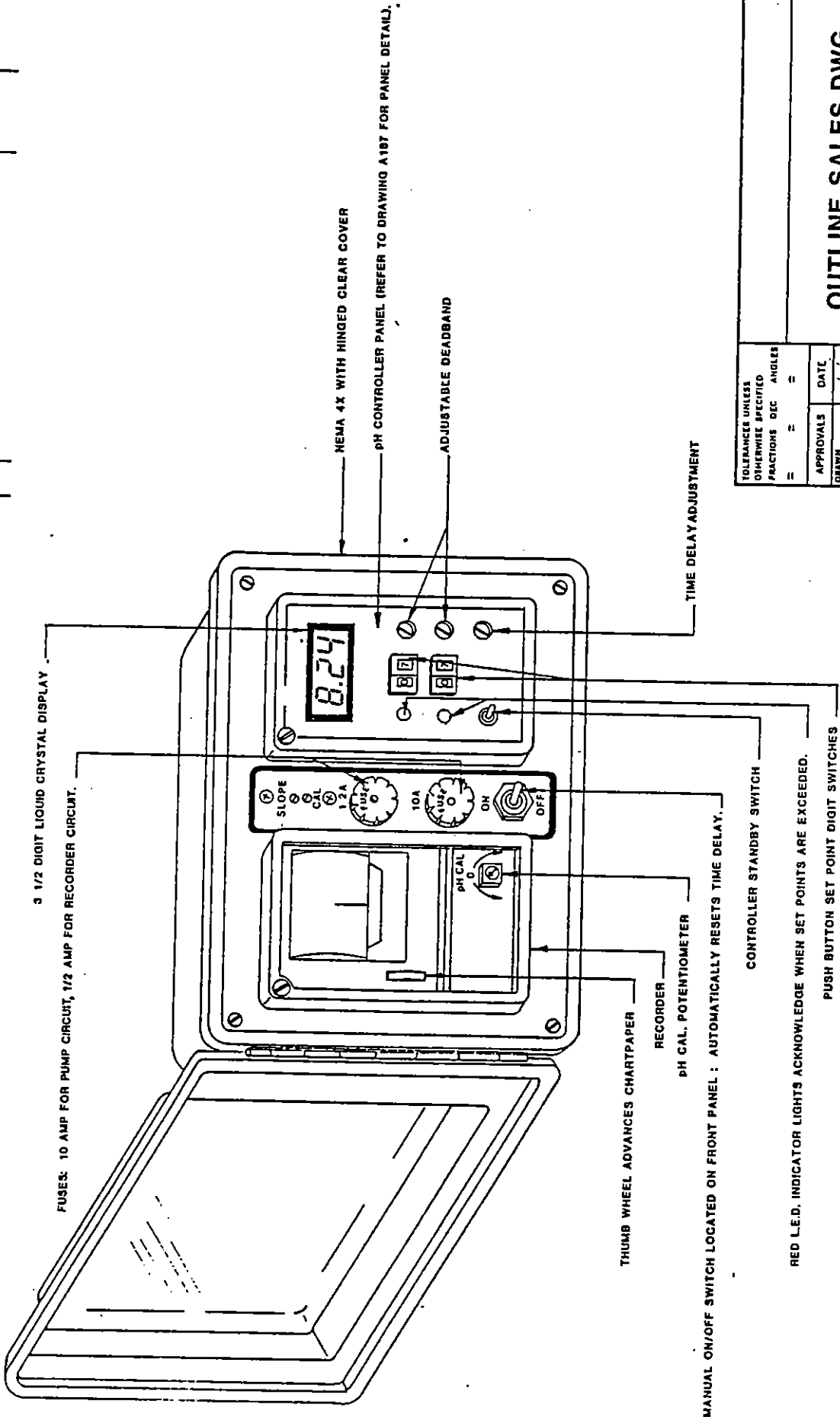

TOLERANCES UNLESS OTHERWISE SPECIFIED	
FRACTIONS DEC ANGLES	
APPROVALS	DATE
DRAWN	11/15/84
CHECKED	11/15/84

**OUTLINE SALES DWG.**

SCALE **B** DRAWING NO. **A 190**

DO NOT SCALE DRAWING SHEET

REVISIONS		DATE	APPROVED
LTR	DESCRIPTION		

**NEMA 4X**

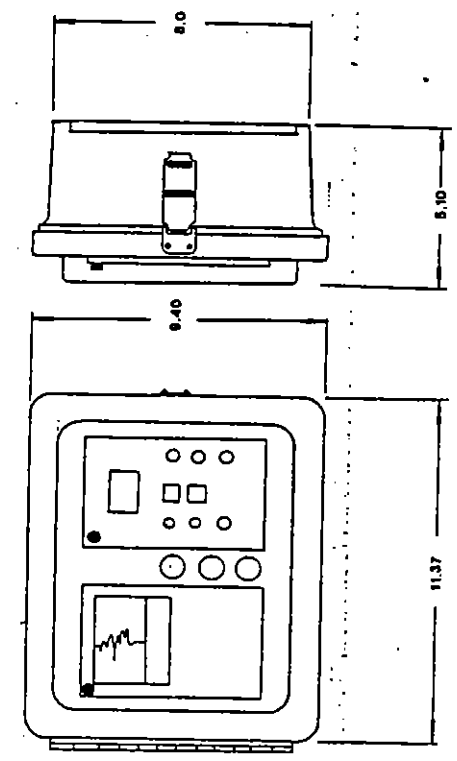

**PANEL/WALL MOUNT**

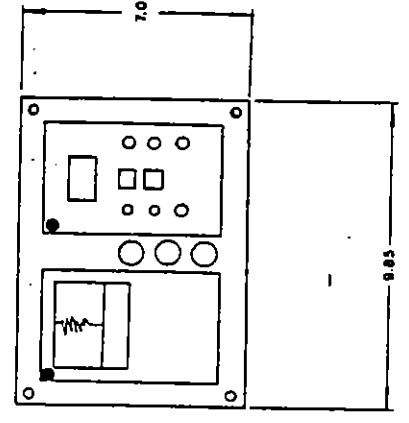

**BENCHTOP**

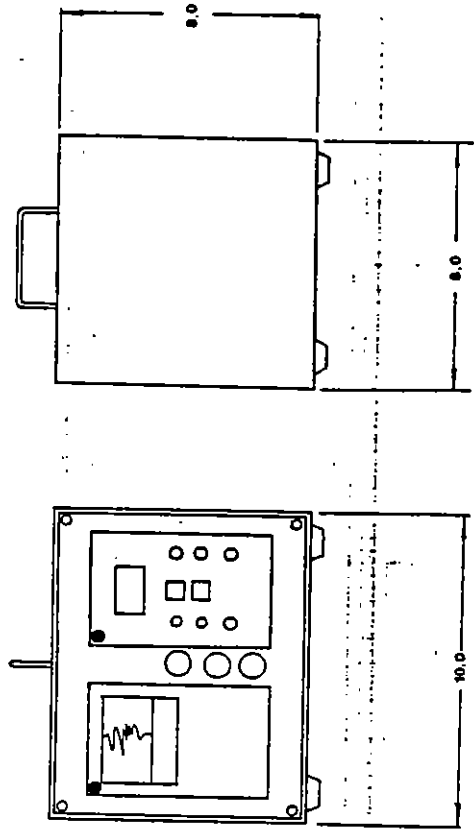

**PANEL CUT OUT**

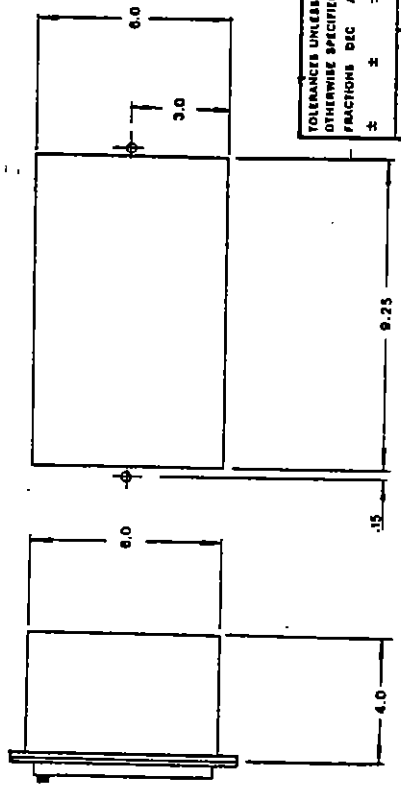

APPROVALS	DATE	SCALE
DRAWN	10-11-76	1:4
CHECKED	11/24/76	

HOUSING OPTIONS DWG.		
SIZE	DRAWING NO.	
B	A195	
DO NOT SCALE DRAWING SHEET		

REVISIONS

DESCRIPTION	DATE	APPROVED
RELOCATE ACTION SWITCHES 1 & 2.	5-11-88	<i>Car</i>

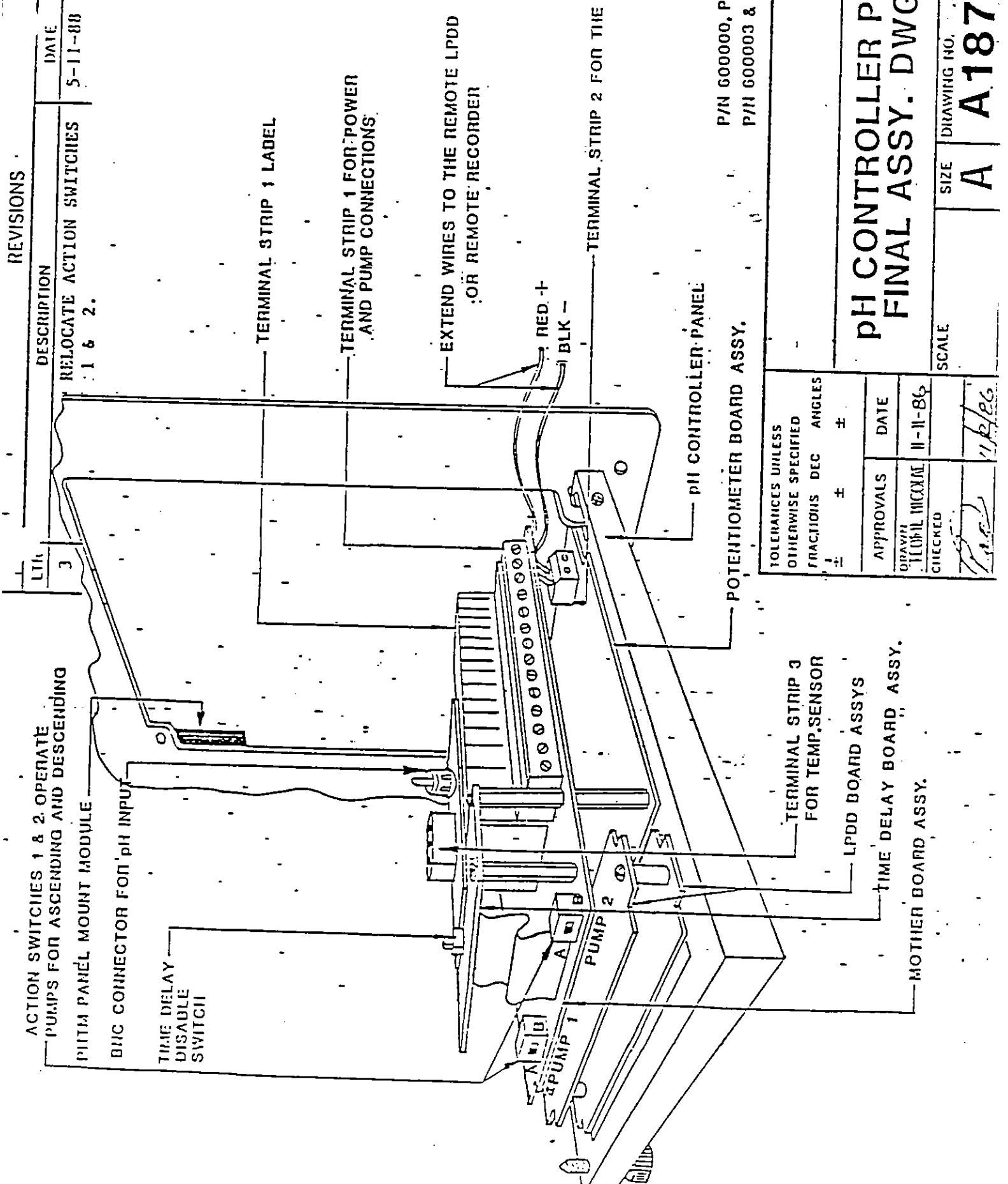

P/N 600000, P/N 600001.  
P/H 600003 & P/N 600004.

TOLERANCES UNLESS OTHERWISE SPECIFIED	FRACTIONS DEC ANGLES	±	±
APPROVALS	DATE		
DRAWN T. L. MICHAEL	11-11-86		
CHECKED			

# PH CONTROLLER PANEL FINAL ASSY. DWG.

SCALE

SIZE **A** DRAWING NO. **A187 a**



REVISIONS

LIR	DESCRIPTION	DATE	APPROVED
B	MODIFIED AND UPDATED	5-11-88	<i>[Signature]</i>
C	CHANGE FROM RELAY	4-22-91	<i>[Signature]</i>

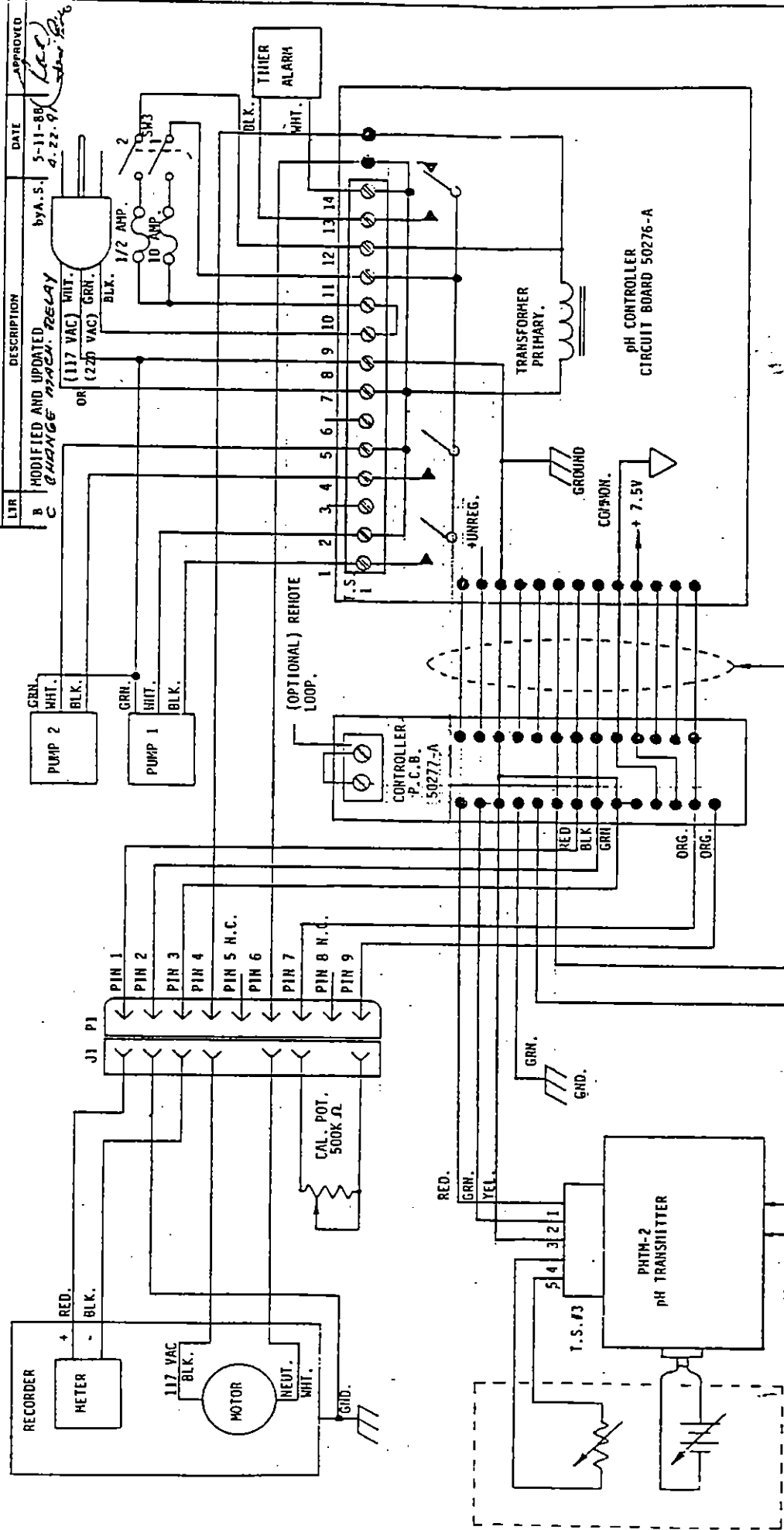

TOLERANCES UNLESS OTHERWISE SPECIFIED		APPROVALS	
FRACTIONS	DEC	DATE	CHECKED
±	±	4-17-86	<i>[Signature]</i>

SCALE		SIZE		DRAWING NO.	
NONE		B		20002-C	

DO NOT SCALE DRAWING

# PRESTO-TEK CORP

PRC-212 WIRING DIAGRAM.

LOOP POWERED DISPLAY.

11.99



## RESISTANCE VS. TEMPERATURE CHART

°C	0	10	20	25	30	40	50	60	70	80	90	100
°F	32	50	68	77	86	104	122	140	158	176	194	212
Ω	1000	1039	1078	1097	1117	1155	1194	1232	1271	1309	1347	1385

# CHART LOADING, RE-ROLL MOD.

A warning to "RENEW CHART" appears on the last three feet of each roll of paper. Do not use partial rolls of paper in re-roll mode. Refer to diagram at left.

- 1) Turn power off before loading chart paper.
- 2) Open recorder by loosening thumbscrew (1).
- 3) Unlatch paper retaining clips (2).
- 4) Open panel to chassis latch (3) RH side plate.
- 5) Remove supply (4) and take up roller (5). If paper is still attached to supply roller, carefully slide the paper from between the front panel and chart drive. Do not pull the paper backwards through the recorder because of the danger of snagging the pointer.
- 6) Insert the supply roller into the new roll of chart paper. The perforated end of the paper is nearest to the roller shoulder.
- 7) Unroll about a foot of paper. Slide the paper between the panel and side plate, sprocket holes first. Keep paper taut and close to the drive drum to prevent snagging the pointer.
- 8) Engage the supply roller shaft in both seating notches (6) and check to be sure that the paper sprocket holes engage the time drum sprockets.
- 9) Slide cardboard sleeve all the way on the take up roller against the disc.
- 10) Butt paper against disc and tape the paper to the sleeve, printed side out. Wrap a few turns of the paper to be sure paper is started true.
- 11) Continue rolling paper and place roller shaft into notches. (Lower notch LH side).
- 12) Close clips (2), latch (3) and recorder front panel. Tighten thumbscrew (1).
- 13) Advance paper with the chart advance wheel (8), to assure that paper moves through the recorder. Set to time.

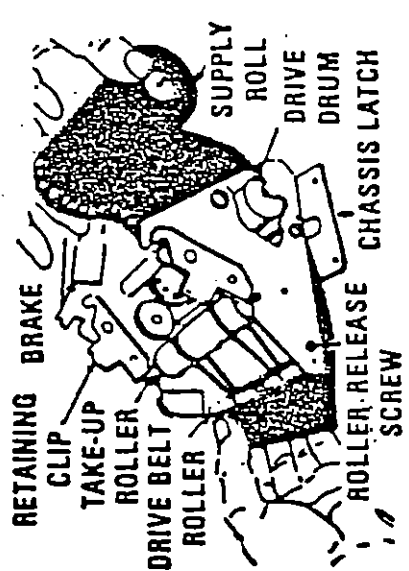
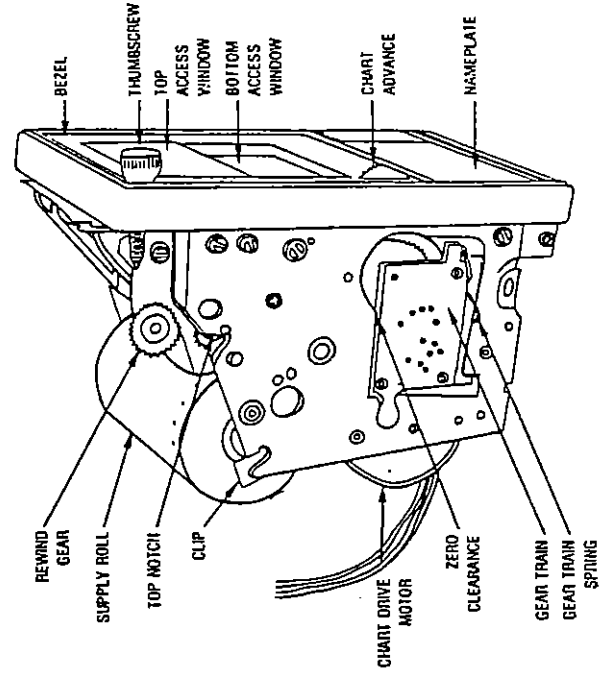
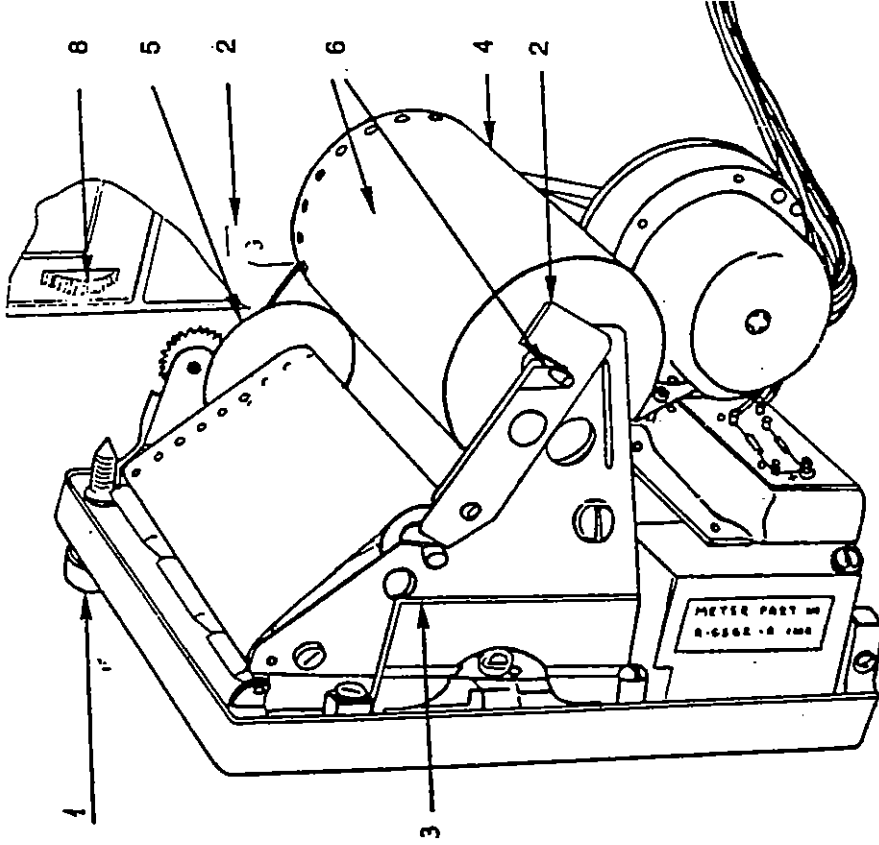

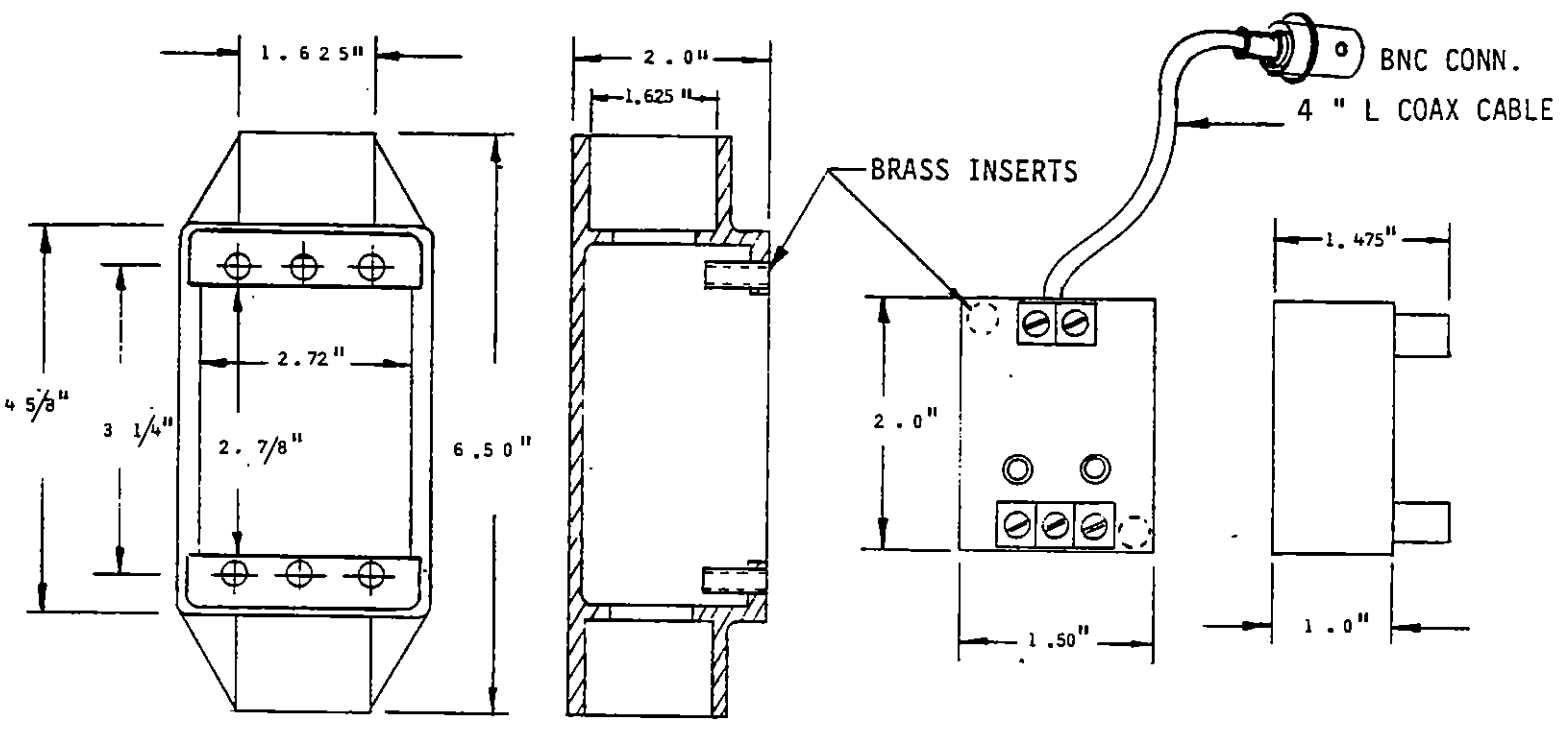

**WALL MOUNT BOX DIMENSIONS**

**PHTM-1 MODULE DIMENSIONS**

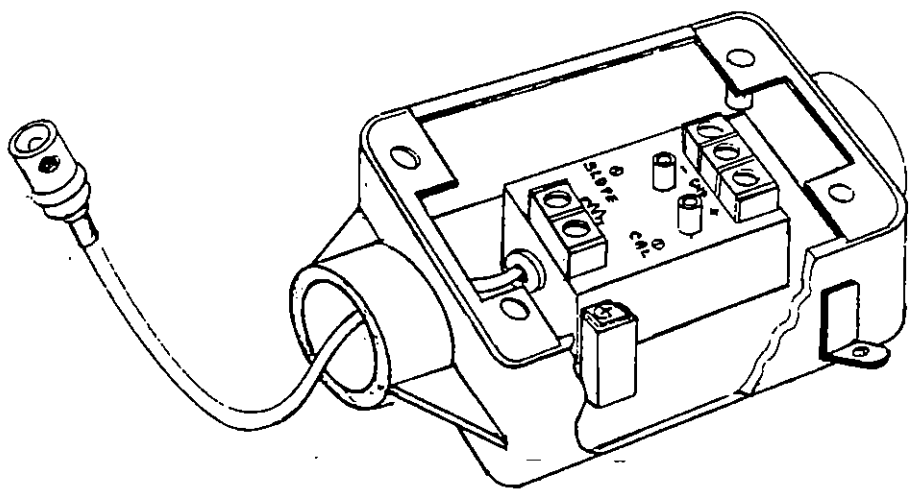

COVER NOT SHOWN  
IN DRAWING

**PHTM-1 IN WALL MOUNT BOX**