

PXTX-507



STRAIN/BRIDGE INPUT 2-WIRE TRANSMITTER WITH 4-20 mA OUTPUT

Instruction Manual



N **NEWPORT** Electronics, Inc.

Additional products from
NEWPORT Electronics, Inc.

Counters
Frequency Meters
PID Controllers
Clock/Timers
Printers
Process Meters
On/Off Controllers
Recorders
Relative Humidity
Transmitters
Thermocouples
Thermistors
Wire

Rate Meters
Timers
Totalizers
Strain Gauge Meters
Voltmeters
Multimeters
Soldering Iron Testers
pH pens
pH Controllers
pH Electrodes
RTDs
Thermowells
Flow Sensors

For Immediate Assistance
In the U.S.A. and Canada: 1-800-NEWPORT®
In Mexico: (95) 800-NEWPORTSM
Or call your local NEWPORT Office.

NEWPORTnetSM On-Line Service
<http://www.newportUS.com>

Internet e-mail
info@newportUS.com

It is the policy of NEWPORT to comply with all worldwide safety and EMC/EMI regulations that apply. NEWPORT is constantly pursuing certification of its products to the European New Approach Directives. NEWPORT will add the CE mark to every appropriate device upon certification.

The information contained in this document is believed to be correct but NEWPORT Electronics, Inc. accepts no liability for any errors it contains, and reserves the right to alter specifications without notice.

WARNING: These products are not designed for use in, and should not be used for, patient connected applications.



This device is marked with the international caution symbol. It is important to read the Setup Guide before installing or commissioning this device as it contains important information relating to safety and EMC.

TABLE OF CONTENTS

	Page
1.0 Getting Started	1
1.1 Unpacking	1
1.2 General Description	1
1.3 Features	1
2.0 Safety Considerations	2
3.0 Configuration	3
3.1 Factory Default Settings	3
3.2 Custom Configuration	3
3.3 Jumper Description	3
4.0 Installation	4
4.1 Physical Mounting	4
4.1.1 Optional Adapters for Mounting	5
4.1.2 Surface and TR2/2TK Relay Track Mounting Procedure	5
4.1.3 DIN EN 50 022 Relay Mounting Procedure	6
4.1.4 External Explosion-Proof Housing Mounting	7
4.2 Power and Signal Input Connections	8
4.3 Screw-Terminal Pin Assignment	8
5.0 Calibration	9
5.1 Normal Calibration	9
5.2 Shunt Calibration	10
5.3 Transducer Simulator Calibration	11
7.0 Specifications	16
7.1 Electrical Specifications	16
7.2 Physical Specifications	17

Figures

	Page
Figure 4-1 Exploded View of Model PXTX-507	4
Figure 4-2 Bulkhead and Track Mounting	5
Figure 4-3 DIN Track Mounting	6
Figure 4-4 Spring Retainer for Explosion-Proof Housing	7
Figure 4-5 Power and Signal Input Connections	8
Figure 7-1 PXTX-507 Case Dimensions	18

Tables

Table 6-1 Gain Jumper Selection for 2.5 K & 5 K Bridges @ 2.5 V	12
Table 6-2 Gain Jumper Selection for 1 K, 2.5 K & 5 K Bridges @ 1.24 V .	12
Table 6-3 Gain Jumper Selection for 500 ohm Bridges @ 1.24 V	13
Table 6-4 Gain Jumper Selection for 350 ohm Bridges @ 1.24 V	13
Table 6-5 Zero Current Jumper Selection @ 1.24 V	14
Table 6-6 Zero Current Jumper Selection @ 2.5 V	14
Table 6-7 Bridge Resistance Jumper Selection	15

1.0 Getting Started

1.1 Unpacking

Remove the packing list and verify that you have received all equipment. If you have any questions, contact the Customer Service Department nearest you.

Upon receipt of shipment, inspect the container and equipment for any signs of damage. Note any evidence of rough handling in transit. Immediately report any damage to the shipping agent.

**Note**

The carrier will not honor any claims unless all shipping material is saved for their examination. After examining and removing contents, save packing material and carton in the event reshipment is necessary.

1.2 General Description

This is a 2-wire, 4-20 mA Current Transmitter that accepts signals from 350, 500, 1K, 2.5K and 5K ohm bridges and provides the amplification and common-mode rejection necessary to control the current drawn from a 8 to 40 Vdc source to produce the 4-20 mA output signal.

The transmitter is designed for 0.5 to 4.0 mV/V bridge sensitivities. The transmitter does not provide isolation between its input and the 4-20 mA output. It has two internal reference voltages for powering the bridge. The 1.24 volt reference is used with 1K ohm and lower resistance bridges. The 2.5 volt reference is used with 2.5K and 5K ohm bridges.

1.3 Features

- Converts mV/V sensor output to 4-20 mA Loop Signal
- 0.5 mV/V to 4.0 mV/V Input Span
- Provides Transducer Excitation (1.24V or 2.5V)
- User Selectable Input Ranges
- Works with 350 ohm to 5K ohm Strain Sensors
- Zero and Span Adjustability
- 8 to 40 Vdc Supply Voltage Range
- Rugged Industrial Housing

2.0 Safety Considerations

This device is marked with the international caution symbol. It is important to read this manual before installing or commissioning this device as it contains important information relating to Safety and EMC (Electromagnetic Compatibility).

Note

- Do not attempt to operate this unit if it is damaged.
- Do not make signal wiring connections or changes when the power is on.
- Make all signal connections before power is applied.
- If connection changes are required, first disconnect the power.
- Do not use this instrument on a work bench without its case for safety reasons.
- Do not operate this instrument in flammable or explosive atmospheres.
- Allow for adequate ventilation to ensure instrument does not exceed the operating temperature rating.
- Use electrical wires with adequate size to handle mechanical strain and power requirements. Install without exposing bare wire outside the connector to minimize electrical shock hazards.
- As with any electronic instrument, you may encounter high voltages when installing, configuring, calibrating or changing the push-on jumpers of the transmitter.
- This instrument has no power-on switch; it will be in operation as soon as the power is connected.
- The transmitter must be tightly secured at the time of installation.

EMC Considerations

- Whenever EMC is an issue, always use shielded cables.
- Never run signal and power wires in the same conduit.
- Use signal wire connections with twisted-pair cables.
- Install Ferrite Bead(s) on signal wires close to the instrument if EMC problems persist.

3.0 Configuration

3.1 Factory Default Settings

The transmitter is factory configured for a 5 K ohm bridge, 2.5 V excitation, and a 3 mV/V input sensitivity. If you desire to configure your unit with other than the standard default settings, see section 3.2 Custom Configuration.

3.2 Custom Configuration

The transmitter may be custom configured for your particular application by means of push-on jumpers located inside the transmitters case. To gain access to the jumpers you must remove the transmitters top cover by removing the four screws holding the cover in place. Select the appropriate push-on jumpers for your application. See section 3.3 Jumper Description for a complete description of each jumper's function.

3.3 Jumper Description

Jumpers A, B, C, D, E, F, G, H, & I are the GAIN Selection Jumpers. These jumpers are selected to match the mV/V sensitivity of the bridge you are using. The selection of these jumpers also depend on the bridge resistance used (e.g. 350, 500, 1 K, 2.5 K, & 5 K ohm) and the excitation voltage selected (e.g. 1.24 V or 2.5 V). Refer to TABLE 6.1 through TABLE 6.4 for the proper selection of these jumpers.

Jumpers J, K, L, & M are the ZERO Current Selection Jumpers. These jumpers select the course ZERO (4.0 mA) output current when the bridge is in a balanced condition. The selection of these jumpers also depend on the bridge resistance used (e.g. 350, 500, 1 K, 2.5 K, & 5 K ohm) and the excitation voltage selected (e.g. 1.24 V or 2.5 V). Refer to TABLE 6.5 or TABLE 6.6 for the proper selection of these jumpers.

Jumpers N & O are the BIAS Selection Jumpers. These jumpers select the amount of bias on the amplifier and are selected to obtain approximately a +0.6 Vdc level at Test Point #3 with respect to ground with a balanced bridge condition. This adjustment has already been done at the factory for the default configuration, but your particular application may require readjustment of this parameter if you experience non-linear operation of the transmitter.

Jumpers P & Q are the Excitation Voltage Selection Jumpers. These jumpers select the excitation voltage as follows: P=2.5 V, Q=1.24 V. Only one of these jumpers should be selected at any one time.

Jumpers R, S, U, & W are the Bridge Resistance Selection Jumpers. These jumpers are selected to match the bridge resistance you are using (e.g. 350, 500, 1 K, 2.5 K, or 5 K ohm). Refer to Table 6.7 for the proper selection of these jumpers.

Jumper T is the Shunt Calibration Selection Jumper. This jumper, when closed, places a known precision resistor (59.0 K, 0.1%) across the bridge, so that a known output is seen, and is used to calibrate the transmitter.

Jumper X is the Bypass Selection Jumper. This jumper is used for factory testing purposes only. This jumper should always be left in the open position which is the default position.

4.0 Installation

After you have properly configured the transmitter for your particular application, using the push-on jumpers, you are now ready to install the transmitter by performing the following steps:

4.1 Physical Mounting

The small size of the transmitter permits mounting in many small spaces. A bulkhead adapter provides for wall-mounting. A snaptrack adapter mounts on either American or European relay tracks. Tapped holes in the case rear provide for custom mounting on any surface. An optional top cover shields the barrier strips from exposed environments. Observe the mounting instructions in the following sections as applicable. The transmitter must be tightly secured at the time of installation.

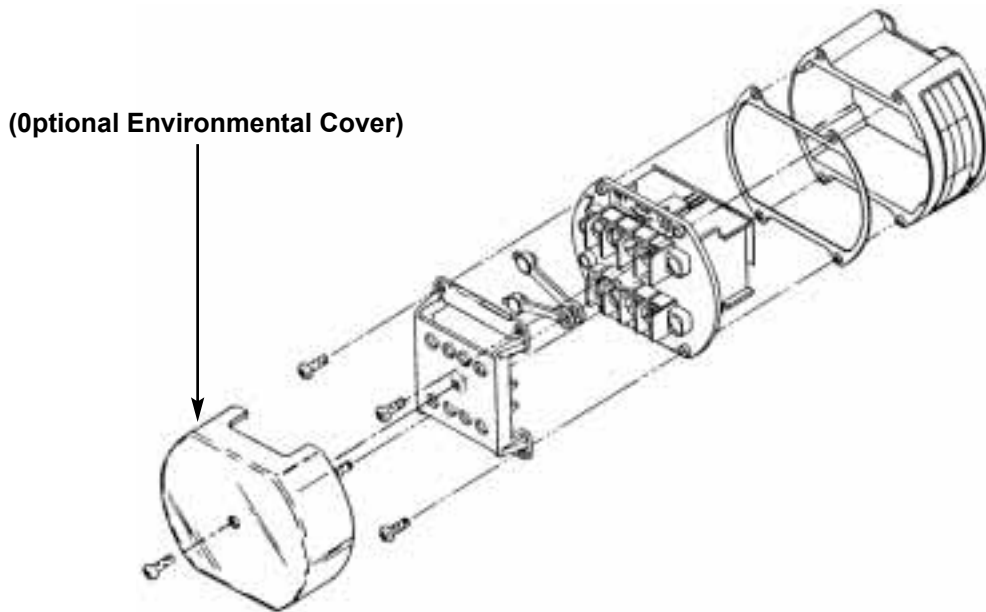

Figure 4.1 Exploded View of Model PXTX-507

The low voltage requirement of the transmitter enables its use with a current-loop indicator (Newport Model 508 recommended). Tapped holes on the back of the case provide for custom mounting to a flat surface; flanges on the back of the case provide for standard 8TK2 relay track mounting. For flat surface mounting, use #6 hardware. For 8TY2 relay track mounting, simply push onto track.

4.1.1 Optional Adapters For Mounting

The following optional adapters provide various mounting choices:

- a. Adaptor plate for either front-screw-entry surface mount, or TR2/2TK relay track mount (see Figure 4.2).
- b. Rail clamp for DIN-EN-50 022 relay track mount (Figure 4.3).
- c. Spring retainers for external 76.4 to 88.9 mm (3 to 3.5 in) explosion-proof housing mount (see Figure 4.4).

4.1.2 Surface and TR2/2TK Relay Track Mounting Procedure

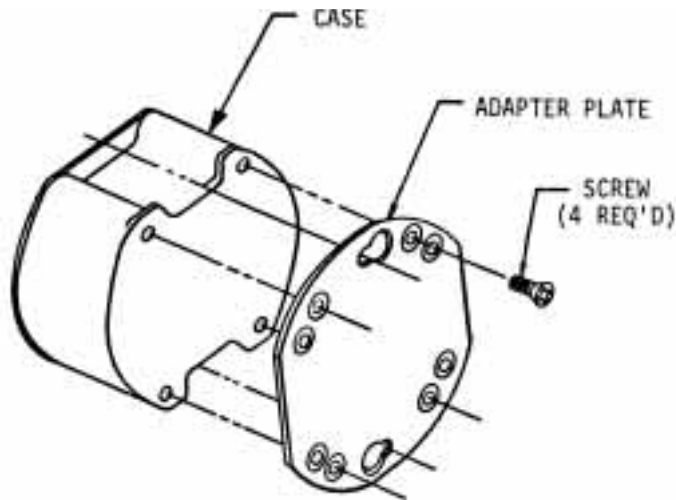

BULKHEAD MTG

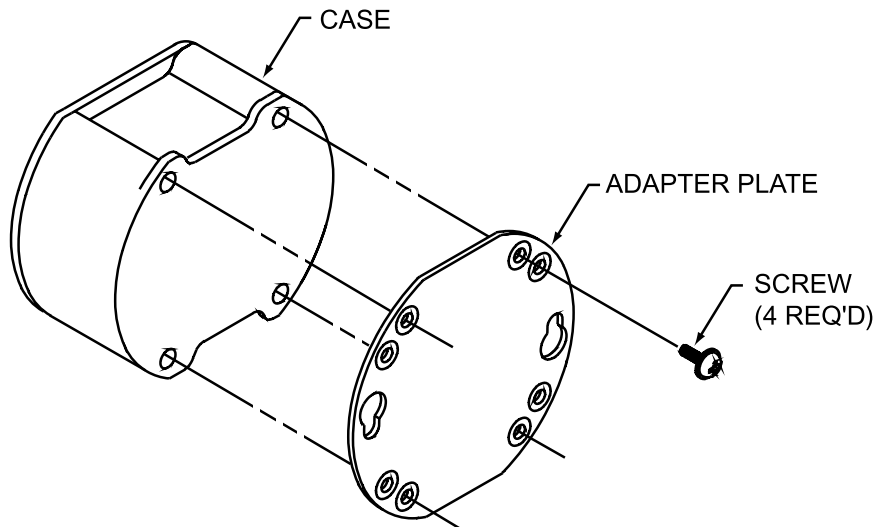

TRACK MTG

Figure 4.2 Bulkhead and Track Mounting

1. Position plate for desired application.
2. Use #6 hardware to mount plate to back of transmitter case.

4.1.3 DIN EN 50 022 Relay Track Mounting Procedure

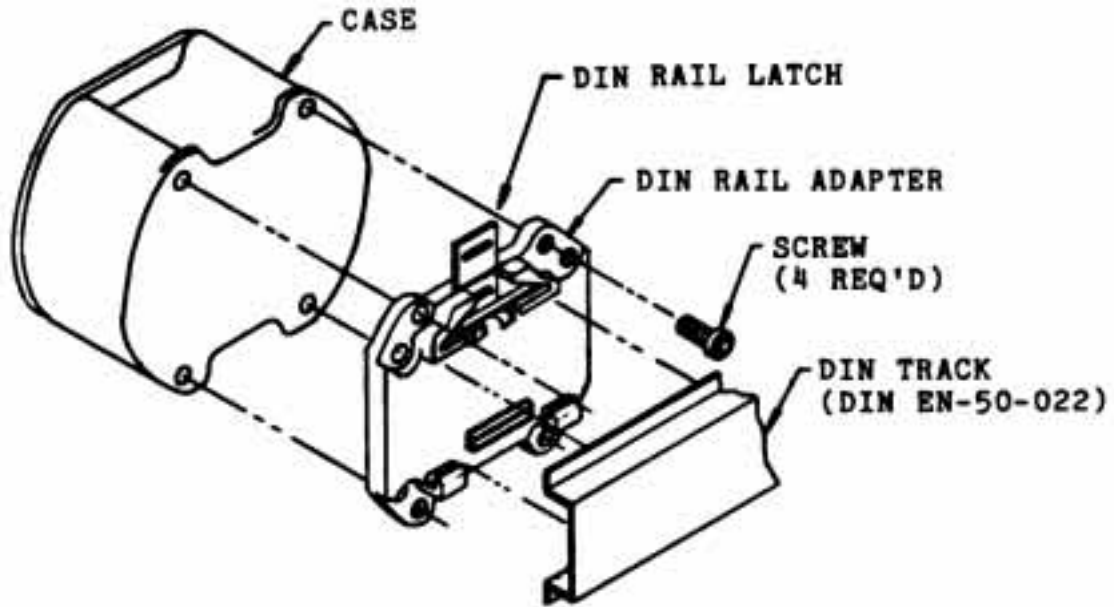

DIN TRACK MTG: SHOWN FOR HORIZONTAL TRACK

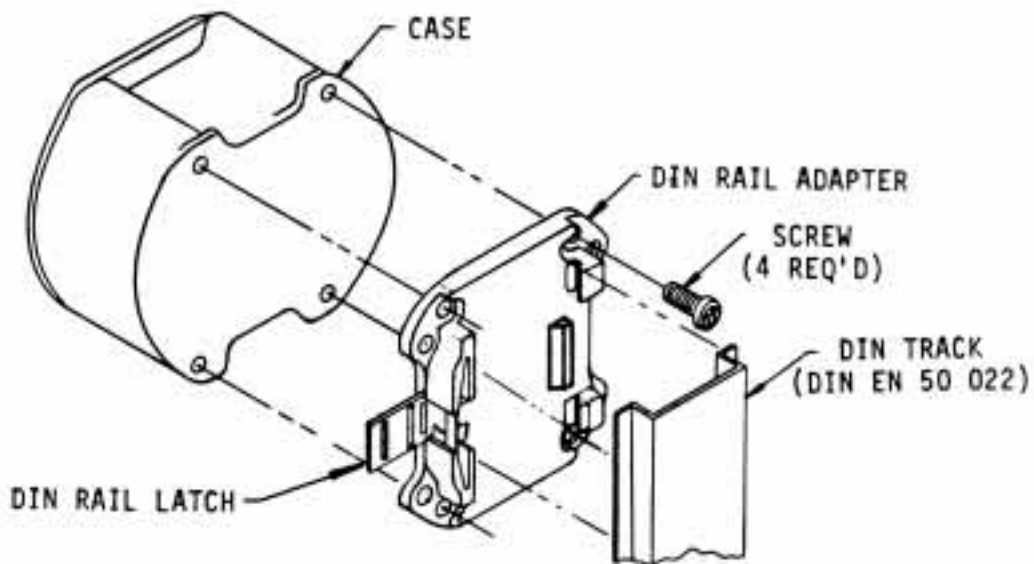

DIN TRACK MTG: SHOWN FOR VERTICAL TRACK

Figure 4.3 DIN Track Mounting

1. Position plate for desired track direction.
2. Use #6 flathead screws to mount plate to back of transmitter case.
3. Snap transmitter case assembly onto DIN rail.

4.1.4 EXTERNAL EXPLOSION-PROOF HOUSING MOUNTING

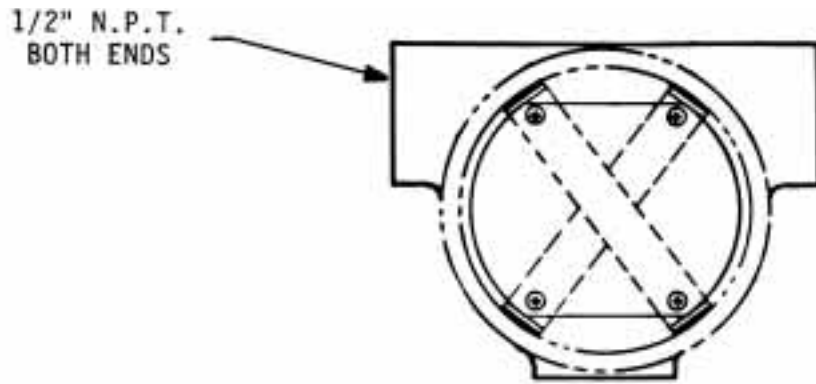

TOP VIEW OF EXPLOSION-PROOF HOUSING UNIT AND HOUSING SHOWN FOR REFERENCE ONLY

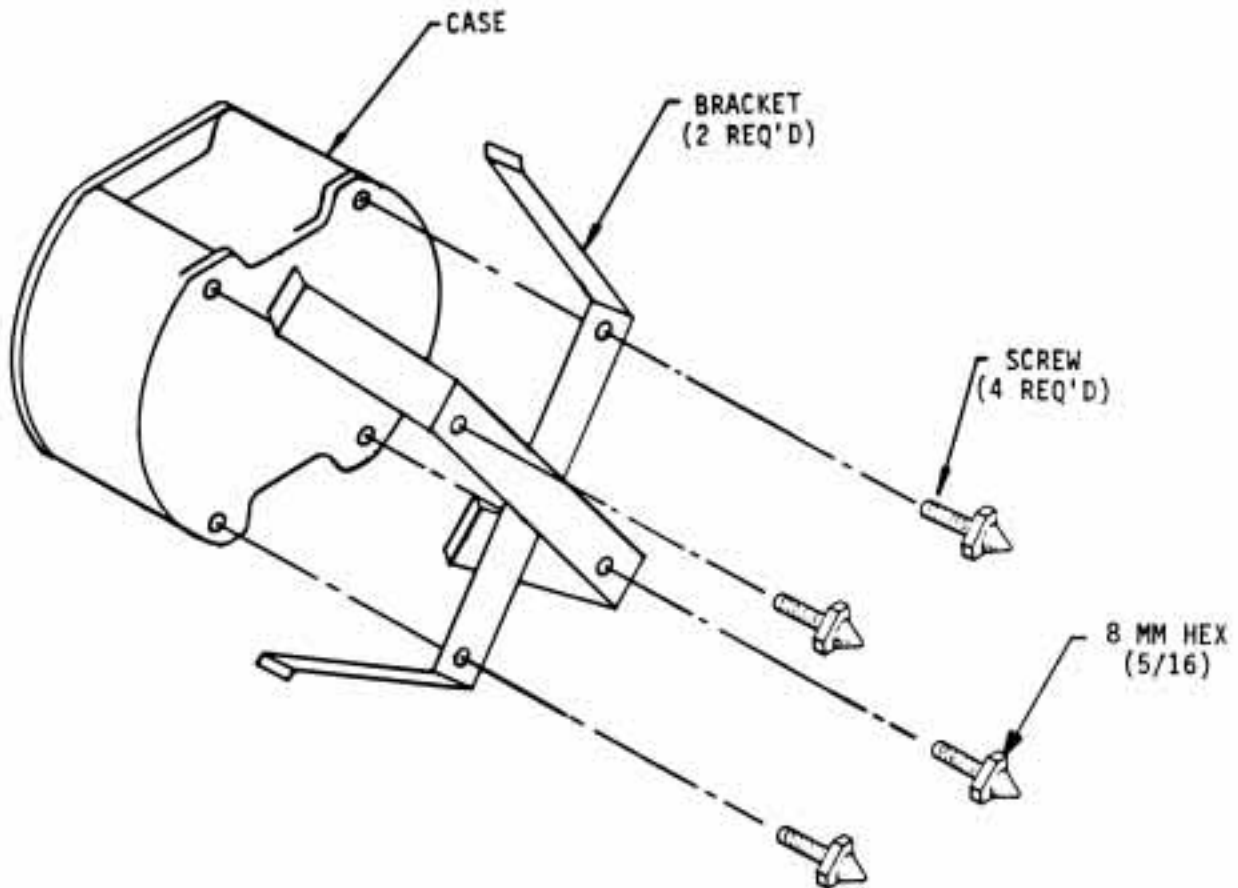

Figure 4.4 Spring Retainer for Explosion-Proof Housing

1. Position spring retainer across back of transmitter case.
2. Use wire protector feet (4 provided with above option) to hold spring retainers in place.
3. Press transmitter case assembly into explosion-proof housing.

4.2 Power and Signal Input Connections

This instrument has no power-on switch; it will be in operation as soon as the power is connected. Make all signal connections before the power is applied. If connection changes are required, first disconnect the power, then make the necessary changes. Connect the transmitter per Figure 4.5 below:

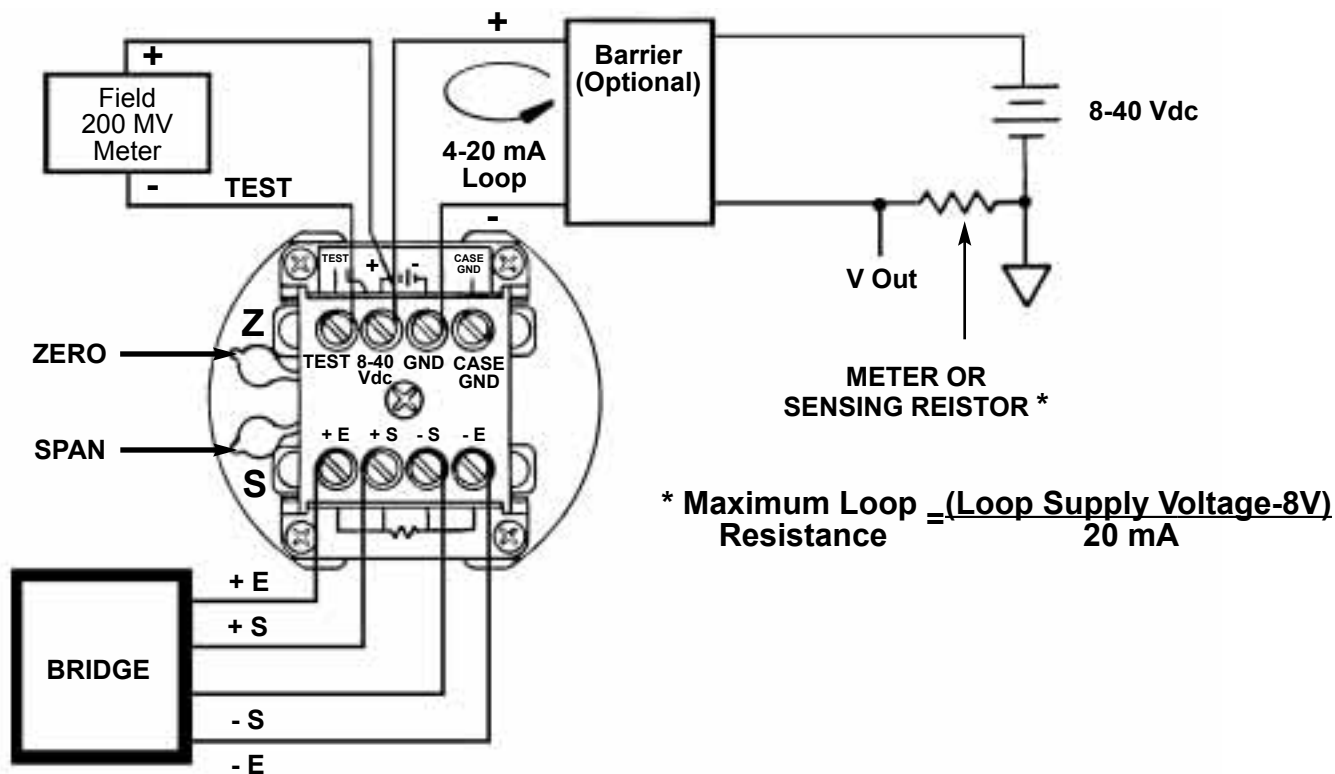

Figure 4.5 Power and Signal Input Connections

4.3 Screw-Terminal Pin Assignment

- | | |
|---|----------------|
| 1 | TEST |
| 2 | + POWER/OUTPUT |
| 3 | - POWER/OUTPUT |
| 4 | CASE GND |
| | |
| A | + E |
| B | + S |
| C | - S |
| D | - E |

TEST, PWR +, and PWR - screws accept 2 mm (13 gauge) or lighter wire. CASE GND is grounded to the case. Power input range is 8-40 Vdc.

5.0 Calibration

After you have properly installed the transmitter, you are now ready to calibrate the instrument. There are basically three different methods that can be used to calibrate the transmitter. The Normal Calibration method (5.1), the Shunt Calibration method (5.2), and the Transducer Simulator Calibration method (5.3). Choose the one calibration method that is most appropriate for your particular application.

5.1 Normal Calibration

Zero Calibration

- 5.1.1 Apply a zero signal to the transmitter from your bridge, strain gauge, load cell, etc.
- 5.1.2 Apply DC power to the transmitter. (8-40 Vdc)
- 5.1.3 Read the output current of the transmitter.
- 5.1.4 If the current read in step 5.1.3 is 4.0 mA +/- 0.4 mA, skip to step 5.1.15.
- 5.1.5 If the current is more than +/- 0.4 mA away from 4.0 mA, then proceed to the following steps.
- 5.1.6 Disconnect DC power from the transmitter.
- 5.1.7 Remove the transmitter's top cover.
- 5.1.8 Remove all the Zero Current Selection Jumpers (J, K, L, & M) from the transmitter.
- 5.1.9 Reapply DC power to the transmitter.
- 5.1.10 Read and note the output current of the transmitter.
- 5.1.11 Look up the current read in step 5.1.10 in Table 6.5 or Table 6.6 and note the jumper selection required to give you approximately 4.0 mA.
- 5.1.12 Disconnect DC power from the transmitter.
- 5.1.13 Place the Zero Current Selection Jumpers as determined in step 5.1.11.
- 5.1.14 Reapply DC power.
- 5.1.15 Adjust the transmitter's Zero pot for an exact indication of 4.0 mA.

Span Calibration

- 5.1.16 Apply a full scale signal to the transmitter from your bridge, strain gauge, load cell, etc.
- 5.1.17 Adjust the transmitter's Span pot for a reading of exactly 20.0 mA.

5.2 Shunt Calibration

Zero Calibration

- 5.2.1 Apply a zero signal to the transmitter from your bridge, strain gauge, load cell, etc.
- 5.2.2 Apply DC power to the transmitter. (8-40 Vdc)
- 5.2.3 Read the output current of the transmitter.
- 5.2.4 If the current read in step 5.2.3 is 4.0 mA +/- 0.4 mA, skip to step 5.2.15.
- 5.2.5 If the current is more than +/- 0.4 mA away from 4.0 mA, then proceed to the following steps.
- 5.2.6 Disconnect DC power from the transmitter.
- 5.2.7 Remove the transmitter's top cover.
- 5.2.8 Remove all the Zero Current Selection Jumpers (J, K, L, & M) from the transmitter.
- 5.2.9 Reapply DC power to the transmitter.
- 5.2.10 Read and note the output current of the transmitter.
- 5.2.11 Look up the current read in step 5.2.10 in Table 6.5 or Table 6.6 and note the jumper selection required to give you approximately 4.0 mA.
- 5.2.12 Disconnect DC power from the transmitter.
- 5.2.13 Place the Zero Current Selection Jumpers as determined in step 5.2.11.
- 5.2.14 Reapply DC power.
- 5.2.15 Adjust the transmitter's Zero pot for an exact indication of 4.0 mA.

Span Calibration

- 5.2.16 If shunt calibration is available on your transducer, proceed with the following steps.
- 5.2.17 Disconnect DC power from the transmitter.
- 5.2.18 Remove the transmitter's top cover.
- 5.2.19 Place the Shunt Calibration Jumper (T) into position.
- 5.2.20 Reapply DC power to the transmitter.
- 5.2.21 Calculate the calibration current using the following formula:

$$\text{Calibration Current} = \frac{\text{Shunt cal output (in mV/V)} \times 20.0 \text{ mA}}{\text{Full-scale output (in mV/V)}}$$

Example: You have a load cell with the following specs.:

Full Scale Output = 3.0220 mV/V

Shunt Cal Output = 2.4176 mV/V

Shunt Cal Resistor = 59 K ohms

$$\text{Calibration Current} = \frac{2.4176 \text{ mV/V} \times 20.0 \text{ mA}}{3.0220 \text{ mV/V}} = 16.0 \text{ mA}$$

- 5.2.22 Adjust the transmitter's Span pot for the Calibration Current calculated in the proceeding step.
- 5.2.23 Disconnect DC power from the transmitter.
- 5.2.24 Remove the transmitter's top cover.
- 5.2.25 Remove the Shunt Calibration Jumper (T) from the transmitter.

5.3 Transducer Simulator Calibration

Zero Calibration

- 5.3.1 Apply a zero signal to the transmitter from a transducer simulator that has the same impedance as your bridge, strain gauge, load cell, etc.
- 5.3.2 Apply DC power to the transmitter. (8-40 Vdc)
- 5.3.3 Read the output current of the transmitter.
- 5.3.4 If the current read in step 5.3.3 is 4.0 mA +/- 0.4 mA, skip to step 5.3.15.
- 5.3.5 If the current is more than +/- 0.4 mA away from 4.0 mA, then proceed to the following steps.
- 5.3.6 Disconnect DC power from the transmitter.
- 5.3.7 Remove the transmitter's top cover.
- 5.3.8 Remove all the Zero Current Selection Jumpers. (J, K, L, & M) From the transmitter.
- 5.3.9 Reapply DC power to the transmitter.
- 5.3.10 Read and note the output current of the transmitter.
- 5.3.11 Look up the current read in step 5.3.10 in Table 6.5 or Table 6.6 and note the jumper selection required to give you approximately 4.0 mA.
- 5.3.12 Disconnect DC power from the transmitter.
- 5.3.13 Place the Zero Current Selection Jumpers as determined in step 5.3.11.
- 5.3.14 Reapply DC power.
- 5.3.15 Adjust the transmitter's Zero pot for an exact indication of 4.0 mA.

Span Calibration

- 5.3.16 Apply a full scale signal to the transmitter from a transducer simulator that has the same impedance as your bridge, strain gauge, load cell, etc.
- 5.3.17 Adjust the transmitter's Span pot for a reading of exactly 20.0 mA.

TABLE 6.1**GAIN JUMPER SELECTION
FOR 2.5 K & 5 K BRIDGES @ 2.5 V**

SENSITIVITY mV/V	A	B	C	D	E	F	G	H	I	
0.437 to 0.534	O	O	X	O	X	X	X	O	O	
0.523 to 0.639	O	O	X	O	O	X	O	X	X	
0.628 to 0.768	O	O	O	X	X	X	O	X	X	X=CLOSED O=OPEN
0.753 to 0.921	O	O	O	X	X	O	O	X	O	
0.905 to 1.106	O	O	O	X	O	X	O	O	O	
1.085 to 1.327	O	O	O	O	X	X	X	O	O	
1.302 to 1.592	O	O	O	O	X	X	O	O	O	
1.562 to 1.910	O	O	O	O	O	X	X	X	O	
1.875 to 2.291	O	O	O	O	O	X	O	X	X	
2.250 to 2.750	O	O	O	O	O	X	O	O	X	
2.700 to 3.300	O	O	O	O	O	O	X	O	X	* DEFAULT
3.240 to 3.960	O	O	O	O	O	O	O	X	X	
3.889 to 4.752	O	O	O	O	O	O	O	X	O	

TABLE 6.2**GAIN JUMPER SELECTION
FOR 1 K, 2.5 K & 5 K BRIDGES @ 1.24 V**

SENSITIVITY mV/V	A	B	C	D	E	F	G	H	I	
0.437 to 0.534	O	X	X	O	O	O	X	X	X	
0.523 to 0.639	O	X	O	X	O	O	X	O	X	
0.628 to 0.768	O	X	O	O	O	O	X	X	O	X=CLOSED O=OPEN
0.753 to 0.921	O	O	X	X	X	O	O	O	X	
0.905 to 1.106	O	O	X	O	X	X	O	X	O	
1.085 to 1.327	O	O	X	O	O	O	X	X	X	
1.302 to 1.592	O	O	O	X	X	X	O	X	O	
1.562 to 1.910	O	O	O	X	X	O	O	O	X	
1.875 to 2.291	O	O	O	X	O	O	X	O	X	
2.250 to 2.750	O	O	O	X	O	O	O	O	O	
2.700 to 3.300	O	O	O	O	X	O	X	O	X	
3.240 to 3.960	O	O	O	O	X	O	O	X	O	
3.889 to 4.752	O	O	O	O	O	X	O	X	X	

TABLE 6.3**GAIN JUMPER SELECTION
FOR 500 OHM BRIDGES @ 1.24 V**

SENSITIVITY mV/V	A	B	C	D	E	F	G	H	I	
0.437 to 0.534	X	O	X	X	X	X	O	X	X	X=CLOSED O=OPEN
0.523 to 0.639	X	O	O	X	X	O	X	O	X	
0.628 to 0.768	X	O	O	O	O	O	O	O	O	
0.753 to 0.921	O	X	X	X	O	O	X	X	X	
0.905 to 1.106	O	X	X	O	O	O	O	X	O	
1.085 to 1.327	O	X	O	X	O	O	O	O	X	
1.302 to 1.592	O	X	O	O	O	O	O	X	X	
1.562 to 1.910	O	O	X	X	O	X	O	X	O	
1.875 to 2.291	O	O	X	O	X	X	O	O	O	
2.250 to 2.750	O	O	X	O	O	X	O	O	O	
2.700 to 3.300	O	O	O	X	X	O	X	X	O	
3.240 to 3.960	O	O	O	X	O	X	O	X	X	
3.889 to 4.752	O	O	O	O	X	X	X	X	X	

TABLE 6.4**GAIN JUMPER SELECTION
FOR 350 OHM BRIDGES @ 1.24 V**

SENSITIVITY mV/V	A	B	C	D	E	F	G	H	I	
0.437 to 0.534	X	X	X	X	X	X	X	X	X	X=CLOSED O=OPEN
0.523 to 0.639	X	X	X	O	X	O	O	O	X	
0.628 to 0.768	X	O	X	X	X	X	O	O	X	
0.753 to 0.921	X	O	O	X	X	O	O	X	X	
0.905 to 1.106	X	O	O	O	O	O	O	O	O	
1.085 to 1.327	O	X	X	X	O	X	O	O	X	
1.302 to 1.592	O	X	O	X	X	X	X	O	X	
1.562 to 1.910	O	X	O	O	X	X	X	O	O	
1.875 to 2.291	O	X	O	O	O	O	O	X	O	
2.250 to 2.750	O	O	X	X	O	O	X	X	X	
2.700 to 3.300	O	O	X	O	X	X	O	O	O	
3.240 to 3.960	O	O	X	O	O	O	X	O	X	
3.889 to 4.752	O	O	O	X	X	O	X	X	O	

TABLE 6.5**ZERO CURRENT JUMPER SELECTION @ 1.24 V**

	<u>mA</u>	<u>JUMPERS</u>				
		<u>J</u>	<u>K</u>	<u>L</u>	<u>M</u>	
	2.5	X	X	X	X	
	2.6	X	X	X	O	
	2.7	X	X	O	X	X=CLOSED
OUTPUT CURRENT	2.8	X	X	O	O	O=OPEN
OF TRANSMITTER	2.9	X	O	X	X	
WITH J, K, L, & M	3.0	X	O	X	O	
JUMPERS REMOVED	3.1	X	O	O	X	
AND A BALANCED	3.2	X	O	O	O	
BRIDGE CONDITION	3.3	O	X	X	X	
	3.4	O	X	X	O	
	3.5	O	X	O	X	
	3.6	O	X	O	O	
	3.7	O	O	X	X	
	3.8	O	O	X	O	
	3.9	O	O	O	X	
	4.0	O	O	O	O	

TABLE 6.6**ZERO CURRENT JUMPER SELECTION @ 2.5 V**

	<u>mA</u>	<u>JUMPERS</u>				
		<u>J</u>	<u>K</u>	<u>L</u>	<u>M</u>	
	1.0	X	X	X	X	
	1.2	X	X	X	O	
	1.4	X	X	O	X	X=CLOSED
OUTPUT CURRENT	1.6	X	X	O	O	O=OPEN
OF TRANSMITTER	1.8	X	O	X	X	
WITH J, K, L, & M	2.0	X	O	X	O	
JUMPERS REMOVED	2.2	X	O	O	X	
AND A BALANCED	2.4	X	O	O	O	
BRIDGE CONDITION	2.6	O	X	X	X	
	2.8	O	X	X	O	
	3.0	O	X	O	X	
	3.2	O	X	O	O	
	3.4	O	O	X	X	
	3.6	O	O	X	O	
	3.8	O	O	O	X	
	4.0	O	O	O	O	

TABLE 6.7

BRIDGE RESISTANCE JUMPER SELECTION

BRIDGE RESISTANCE (OHMS)	JUMPERS				X=CLOSED O=OPEN
	<u>U</u>	<u>W</u>	<u>S</u>	<u>R</u>	
350	O	O	O	O	
500	O	X	O	X	
1 K	X	O	X	O	
2.5 K	X	O	X	O	
5 K	X	O	X	O	

7.0 Specifications

7.1 Electrical Specifications

Input Span:	0.5 mV/V to 4.0 mV/V (User Selectable)
Input Impedance:	Greater than 10 M ohms
Output Span:	4 to 20 mA
Minimum Output Current:	3.75 mA typical
Maximum Output Current:	22 mA typical
Supply Voltage Range:	8 to 40 Vdc
Transducer Excitation:	1.24 Vdc or 2.50 Vdc (User Selectable)
Zero & Span Adjustability:	20% of any selected range
Accuracy:	0.5% of any adjusted span (includes linearity, hysteresis, stability)
Repeatability:	0.05% of span
Response Time:	200 ms typical
Stability:	Zero: within 0.02% of span/°C or 5 uA (whichever is greater) Span: within 0.01% of span/° C
Max. Leadwire Resistance Effect:	Less than 0.25 uV per ohm
Max. Change-In-Supply Voltage Effect:	0.05% of span
Output Ripple:	Less than 0.1% of span, rms
Maximum Loop Resistance:	$\frac{\text{Loop Supply Voltage} - 8 \text{ V}}{20 \text{ mA}}$

7.2 Physical Specifications

Operating Temperature:	-45 to 85°C (-49 to 185°F)
Storage Temperature:	-50 to 90°C (-58 to 194°F)
Humidity:	Waterproof
Vibration:	1.52 mm (0.06 in) double amplitude, 10-80 Hz cycled
Shock:	55 g, half-sine, 9-13 msec duration, 6 foot drop to hard surface
Watertight pressure limit:	35 kPa (5 PSI)
Mounting position:	Any
Case material:	Zamac (zinc alloy), polyurethane-coated, fluorosilicone-gasketed
Weight:	300 g (10 oz)
Diameter:	74 mm (2.9 in)
Height (including barriers):	52 mm (2.1 in)
Connections:	#6 screws with wire clamps

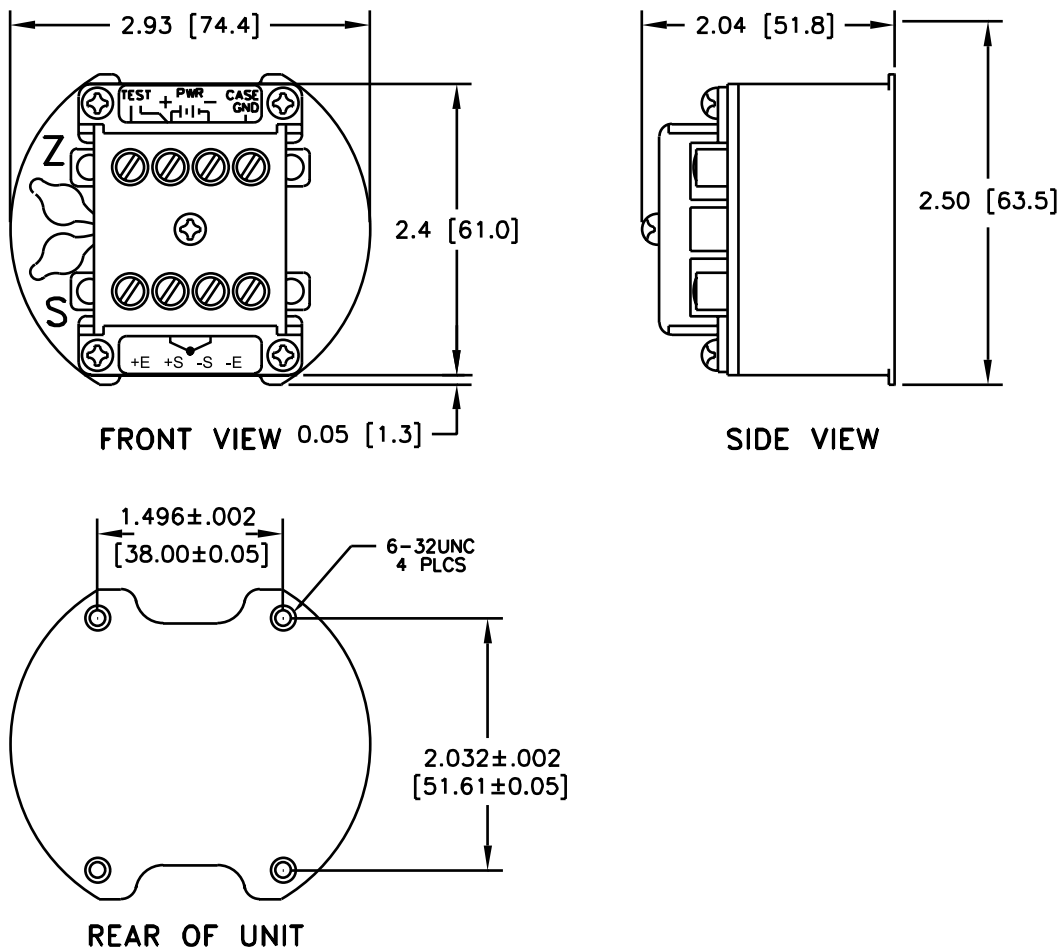

Figure 7.1 PXTX-507 Case Dimensions

Warranty/Disclaimer

NEWPORT ELECTRONICS, INC. warrants this unit to be free of defects in materials and workmanship for a period of one (1) year from date of purchase. In addition to NEWPORT's standard warranty period, NEWPORT ELECTRONICS will extend the warranty period for one (1) additional year if the warranty card enclosed with each instrument is returned to NEWPORT.

If the unit should malfunction, it must be returned to the factory for evaluation. NEWPORT's Customer Service Department will issue an Authorized Return (AR) number immediately upon phone or written request. Upon examination by NEWPORT, if the unit is found to be defective it will be repaired or replaced at no charge. NEWPORT's WARRANTY does not apply to defects resulting from any action of the purchaser, including but not limited to mishandling, improper interfacing, operation outside of design limits, improper repair, or unauthorized modification. This WARRANTY is VOID if the unit shows evidence of having been tampered with or shows evidence of being damaged as a result of excessive corrosion; or current, heat, moisture or vibration; improper specification; misapplication; misuse or other operating conditions outside of NEWPORT's control. Components which wear are not warranted, including but not limited to contact points, fuses, and triacs.

NEWPORT is pleased to offer suggestions on the use of its various products. However, NEWPORT neither assumes responsibility for any omissions or errors nor assumes liability for any damages that result from the use of its products in accordance with information provided by NEWPORT, either verbal or written. NEWPORT warrants only that the parts manufactured by it will be as specified and free of defects. NEWPORT MAKES NO OTHER WARRANTIES OR REPRESENTATIONS OF ANY KIND WHATSOEVER, EXPRESSED OR IMPLIED, EXCEPT THAT OF TITLE, AND ALL IMPLIED WARRANTIES INCLUDING ANY WARRANTY OF MERCHANTABILITY AND FITNESS FOR A PARTICULAR PURPOSE ARE HEREBY DISCLAIMED. LIMITATION OF LIABILITY: The remedies of purchaser set forth herein are exclusive and the total liability of NEWPORT with respect to this order, whether based on contract, warranty, negligence, indemnification, strict liability or otherwise, shall not exceed the purchase price of the component upon which liability is based. In no event shall NEWPORT be liable for consequential, incidental or special damages.

CONDITIONS: Equipment sold by NEWPORT is not intended to be used, nor shall it be used: (1) as a "Basic Component" under 10 CFR 21 (NRC), used in or with any nuclear installation or activity; or (2) in medical applications or used on humans. Should any Product(s) be used in or with any nuclear installation or activity, medical application, used on humans, or misused in any way, NEWPORT assumes no responsibility as set forth in our basic WARRANTY/DISCLAIMER language, and additionally, purchaser will indemnify NEWPORT and hold NEWPORT harmless from any liability or damage whatsoever arising out of the use of the Product(s) in such a manner.

Return Requests/Inquiries

Direct all warranty and repair requests/inquiries to the NEWPORT Customer Service Department. BEFORE RETURNING ANY PRODUCT(S) TO NEWPORT, PURCHASER MUST OBTAIN AN AUTHORIZED RETURN (AR) NUMBER FROM NEWPORT'S CUSTOMER SERVICE DEPARTMENT (IN ORDER TO AVOID PROCESSING DELAYS). The assigned AR number should then be marked on the outside of the return package and on any correspondence.

The purchaser is responsible for shipping charges, freight, insurance and proper packaging to prevent breakage in transit.

FOR **WARRANTY** RETURNS, please have the following information available BEFORE contacting NEWPORT:

1. P.O. number under which the product was PURCHASED,
2. Model and serial number of the product under warranty, and
3. Repair instructions and/or specific problems relative to the product.

FOR **NON-WARRANTY** REPAIRS, consult NEWPORT for current repair charges. Have the following information available BEFORE contacting NEWPORT:

1. P.O. number to cover the COST of the repair,
2. Model and serial number of product, and
3. Repair instructions and/or specific problems relative to the product.

NEWPORT's policy is to make running changes, not model changes, whenever an improvement is possible. This affords our customers the latest in technology and engineering.

NEWPORT is a registered trademark of NEWPORT ELECTRONICS, INC.

© Copyright 2000 NEWPORT ELECTRONICS, INC. All rights reserved. This document may not be copied, photocopied, reproduced, translated, or reduced to any electronic medium or machine-readable form, in whole or in part, without prior written consent of NEWPORT ELECTRONICS, INC.

For immediate technical or application assistance please call:

1-800-6397678®
1-800-NEWPORT

Newport Electronics, Inc.
2229 South Yale Street • Santa Ana, CA • 92704 • U.S.A.
TEL: (714) 540-4914 • FAX: (714) 546-3022
Toll Free: 1-800-639-7678 • <http://www.newportUS.com> • e-mail: info@newportUS.com
ISO 9001 Certified

Newport Technologies, Inc.
976 Bergar • Laval (Quebec) • H7L 5A1 • Canada
TEL: (514) 335-3183 • FAX: (514) 856-6886
Toll Free: 1-800-639-7678 • <http://www.newport.ca> • e-mail: sales@newport.ca

Newport Electronics, Ltd.
One Omega Drive • River Bend Technology Centre
Northbank, Irlam • Manchester M44 5EX • United Kingdom
Tel: +44 (0) 161 777 6611 • FAX: +44 (0) 161 777 6622
Toll Free: 0800 488 488 • <http://www.newportuk.co.uk> • e-mail: sales@newportuk.co.uk

Newport Electronics B.V.
Postbus 8034 • 1180 LA Amstelveen • The Netherlands
TEL: +31 (0)20 3472121 • FAX: +31 (0)20 6434643
Toll Free: 0800 0993344 • <http://www.omega.com> • e-mail: nl@omega.com

Newport Electronics spol s.r.o.
Rudé armády 1868, 733 01 Karviná 8 • Czech Republic
TEL: +420 (0)69 6311899 • FAX: +420 (0)69 6311114
Toll Free: 0800-1-66342 • <http://www.newport.cz> • e-mail: sales@newport.cz

Newport Electronics GmbH
Daimlerstrasse 26 • D-75392 Deckenpfronn • Germany
TEL: 49 (0)7056 9398-0 • FAX: 49 (0)7056 9398-29
Toll Free: 0800 / 6397678 • <http://www.newport.de> • e-mail: sales@newport.de

Newport Electronique S.A.R.L.
9, rue Denis Papin • 78190 Trappes • France
TEL: +33 (0)130 621 400 • FAX: +33 (0)130 699 120
Toll Free: 0800-4-06342 • <http://www.newport.fr> • e-mail: sales@newport.fr

Mexico and Latin America
TEL: 001-800-826-6342 • FAX: 001 (203) 359-7807
En Español: 001 (203) 359-7803

NEWPORTnetSM On-Line Service www.newportUS.com	Internet e-mail info@newportUS.com
--	--

 **NEWPORT** Electronics, Inc.