

**FLOW CHART**

To the right is a flowchart showing how to navigate through all top level menus by pressing the **↶** and **↷** buttons.

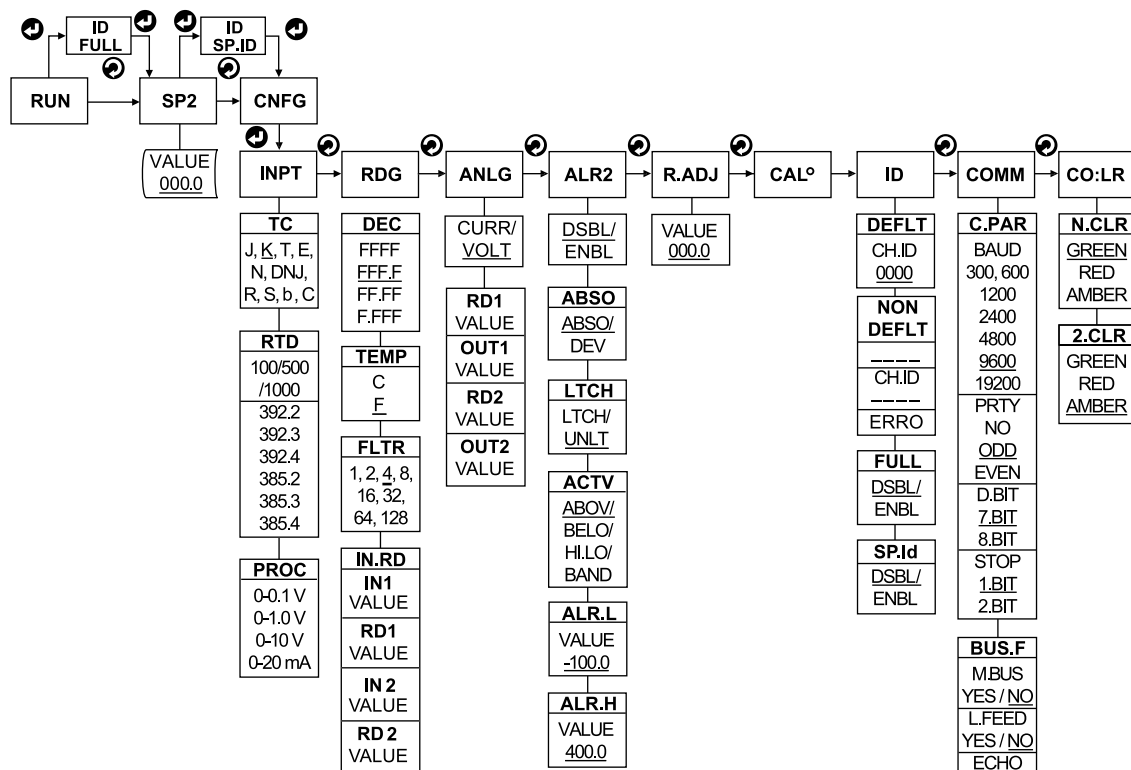

Underline denotes factory default setup

**INPUT MENU SETUP (operation example)**

Below is a flowchart showing how to navigate through the submenus of Input menu item by pressing the front buttons.

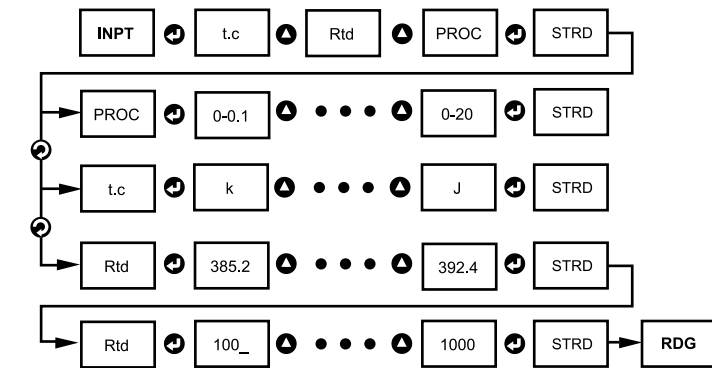

**DISPLAY COLOR SETUP (examples)**

**Example 1:**  
Alarm 2 setup: Absolute, Above, Alarm 2 HI Value "ALR.H" =200  
Color Display setup: Normal Color "N.CLR"=Green, Alarm 2 Color "2.CLR"=Red

Display color change sequence:

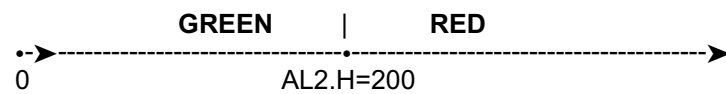

**Example 2:**  
Alarm 2 setup: Deviation, Hi/Low, "ALR.H = 10", "ALR.L = 5"  
Color Display setup: "N.CLR"=Green, "2.CLR"=Amber

Display color change sequence:



**SPECIFICATION**

**Accuracy:** ±0.5°C temp; 0.03% rdg. process typical  
**Resolution:** 1°/0.1°; 10 µV process  
**Temperature Stability:** 0.04°C/°C RTD; 0.05°C/°C TC @ 25°C (77°F); 50 ppm/°C process  
**iDRP Remote Programmer/Display Option:** 4-digit, 9-segment LED 21 mm (0.83"), 48H x 96W x 39D (1.89 x 3.78 x 1.55"), 159g (0.35lbs). Red, green, and amber programmable colors for process variable, set point and temperature units.  
**Input Types:** Thermocouple, RTD, Analog Voltage and Current  
**TC: (ITS 90)** J, K, T, E, R, S, B, C, N, L  
**RTD: (ITS 68)** 100/500/1000 ohm Pt sensor 2-, 3-, or 4-wire; 0.00385 or 0.00392 curve  
**Input Impedance:** 10 MΩ for 100 mV, 1 MΩ for 1 or 10 Vdc  
**Voltage:** 0 to 100 mV (±50 mV), 0 to 1 V, 0 to 10 Vdc  
**Current:** 0 to 20 mA (5 Ω load)  
**WARNING:** These products are not designed for use in, and should not be used for, patient-connected applications.

**WARNING:** This device is marked with the international caution symbol. It is important to read the Setup Guide before installing or commissioning this device, as the guide contains important information relating to safety and EMC.

It is the policy of NEWPORT to comply with all worldwide safety and EMC/EMI regulations that apply. NEWPORT is constantly pursuing certification of its products to the European New Approach Directives. NEWPORT will add the CE mark to every appropriate device upon certification. The information contained in this document is believed to be correct, but NEWPORT Electronics, Inc. accepts no liability for any errors it contains, and reserves the right to alter specifications without notice.

**TRADEMARK NOTICE:** NEWPORT, NEWPORT, newportUS.com and the "Meter Bezel Design" are Trademarks of NEWPORT ELECTRONICS, INC.

**WARRANTY/DISCLAIMER**  
 NEWPORT Electronics, Inc. warrants this unit to be free of defects in materials and workmanship for a period of one (1) year from the date of purchase. In addition to NEWPORT's standard warranty period, NEWPORT Electronics will extend the warranty period for four (4) additional years if the warranty card enclosed with each instrument is returned to NEWPORT.  
 If the unit malfunctions, it must be returned to the factory for evaluation. NEWPORT's Customer Service Department will issue an Authorized Return (AR) number immediately upon phone or written request. Upon examination by NEWPORT, if the unit is found to be defective, it will be repaired or replaced at no charge. NEWPORT's WARRANTY does not apply to defects resulting from any action of the purchaser, including but not limited to mishandling, improper interfacing, operation outside of design limits, improper repair, or unauthorized modification. This WARRANTY is VOID if the unit shows evidence of having been tampered with or shows evidence of having been damaged as a result of excessive corrosion; or current, heat, moisture or vibration; improper specification; misapplication; misuse or other operating conditions outside of NEWPORT's control. Components which wear are not warranted, including but not limited to contact points, fuses, and triacs.  
 NEWPORT is pleased to offer suggestions on the use of its various products. However, NEWPORT neither assumes responsibility for any omissions or errors nor assumes liability for any damages that result from the use of its products in accordance with information provided by NEWPORT, either verbal or written. NEWPORT warrants only that the parts manufactured by it will be as specified and free of defects.  
 NEWPORT MAKES NO OTHER WARRANTIES OR REPRESENTATIONS OF ANY KIND WHATSOEVER, EXPRESS OR IMPLIED, EXCEPT THAT OF TITLE, AND ALL IMPLIED WARRANTIES INCLUDING ANY WARRANTY OF MERCHANTABILITY AND FITNESS FOR A PARTICULAR PURPOSE ARE HEREBY DISCLAIMED.  
**LIMITATION OF LIABILITY:** The remedies of purchaser set forth herein are exclusive, and the total liability of NEWPORT with respect to this order, whether based on contract, warranty, negligence, indemnification, strict liability or otherwise, shall not exceed the purchase price of the component upon which liability is based. In no event shall NEWPORT be liable for consequential, incidental or special damages.  
**CONDITIONS:** Equipment sold by NEWPORT is not intended to be used, nor shall it be used: (1) as a "Basic Component" under 10 CFR 21 (NRC), used in or with any nuclear installation or activity; or (2) in medical applications or used on humans. Should any Product(s) be used in or with any nuclear installation or activity, medical application, or used on humans, or misused in any way, NEWPORT assumes no responsibility as set forth in our basic WARRANTY/DISCLAIMER language, and, additionally purchaser will indemnify NEWPORT and hold NEWPORT harmless from any liability or damage whatsoever arising out of the use of the Product(s) in such a manner.

**RETURN REQUEST/INQUIRIES**  
 Direct all warranty and repair requests/inquiries to the NEWPORT Customer Service Department. BEFORE RETURNING ANY PRODUCT(S) TO NEWPORT, PURCHASER MUST OBTAIN AN AUTHORIZED RETURN (AR) NUMBER FROM NEWPORT'S CUSTOMER SERVICE DEPARTMENT (IN ORDER TO AVOID PROCESSING DELAYS). The assigned AR number should then be marked on the outside of the return package and on any correspondence.  
 The purchaser is responsible for shipping charges, freight, insurance and proper packaging to prevent breakage in transit.  
**FOR WARRANTY RETURNS,** please consult NEWPORT for current repair BEFORE contacting NEWPORT:  
**FOR NON-WARRANTY REPAIRS,** have the following information available charges. Have the following information available BEFORE contacting NEWPORT:  
 1. Purchase Order number under which the product was PURCHASED,  
 2. Model and serial number of the product under warranty, and  
 3. Repair instructions and/or specific problems relative to the product.  
 1. Purchase Order number to cover the COST the repair,  
 2. Model and serial number of product, and  
 3. Repair instructions and/or specific problems relative to the product.  
 NEWPORT's policy is to make running changes, not model changes, whenever an improvement is possible. This affords our customers the latest in technology and engineering.  
 NEWPORT is a registered trademark of NEWPORT Electronics, Inc.  
 © Copyright 2006 NEWPORT Electronics, Inc. All rights reserved.  
**PATENT NOTICE:** This product is covered by one or more of the following patents: U.S. Pat. No. Des. 336,895; 5,274,577; 6,243,021 / Canada 2052599; 2052600 / Italy 1249456; 1250938 / France Brevet No. 91 12756 / Spain 2039150; 2048066 / UK Patent No. GB2 249 837; GB2 248 954 / Germany DE 41 34398 C2. The is a Trademark of OMEGA Engineering, Inc. USED UNDER LICENSE. Other U.S. and International patents pending or applied for.

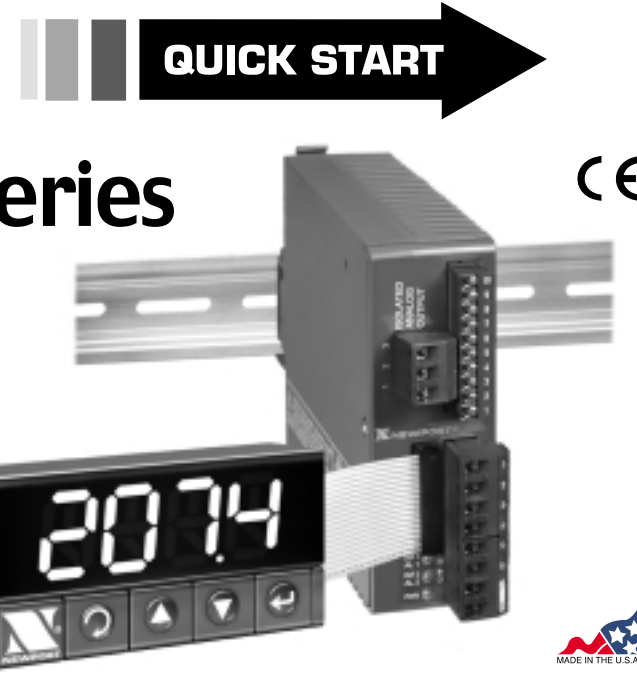

**DIN Rail Temperature/Process with Isolated Analog Output iDRA Monitor or iDRA0x-AL Limit Alarm**

For immediate technical or application assistance please call:

**1-800-6397678®**  
**1-800-NEWPORT**

Newport Electronics, Inc.  
 2229 South Yale Street • Santa Ana, CA • 92704 • U.S.A.  
 TEL: (714) 540-4914 • FAX: (203) 968-7311  
 Toll Free: 1-800-639-7678 • www.newportUS.com • e-mail: info@newportUS.com  
 ISO 9001 Certified

Newport Technologies, Inc.  
 976 Bergar • Laval (Quebec) • H7L 5A1 • Canada  
 TEL: (514) 335-3183 • FAX: (514) 856-6886  
 Toll Free: 1-800-639-7678 • www.newport.ca • e-mail: info@newport.ca

Newport Electronics, Ltd.  
 One Omega Drive • River Bend Technology Centre  
 Northbank, Irlam • Manchester M44 5BD • United Kingdom  
 Tel: +44 161 777 6611 • FAX: +44 161 777 6622  
 Toll Free: 0800 488 488 • www.newportuk.co.uk • e-mail: sales@newportuk.co.uk

Newport Electronics spol s.r.o.  
 Frystatska 184, 733 01 Karviná • Czech Republic  
 TEL: +420 59 6311899 • FAX: +420 59 6311114  
 Toll Free: 0800-1-66342 • www.newport.cz • e-mail: info@newport.cz

Newport Electronics GmbH  
 Daimlerstrasse 26 • D-75392 Deckenpfronn • Germany  
 TEL: 49 7056 9398-0 • FAX: 49 7056 9398-29  
 Toll Free: 0800 / 6397678 • www.newport.de • e-mail: sales@newport.de

Mexico and Latin America  
 FAX: 001 (203) 359-7807  
 En Español: 001 (203) 359-7803

**NEWPORTnet™ On-Line Service** www.newportUS.com  
**Internet e-mail** info@newportUS.com





This Quick Start Reference provides information on setting up your instrument for basic operation. The latest complete Communication and Operational Manual as well as free Software are available at [www.newportUS.com/i](http://www.newportUS.com/i) or on the CD-ROM enclosed with your shipment.

### SAFETY CONSIDERATION



This device is marked with the international Caution symbol.

The instrument is protected in accordance with EN 61010-1:2001, electrical safety requirements for electrical equipment for measurement, control and laboratory. Remember that the unit has no power-on switch. Building installation should include a switch or circuit-breaker that must be compliant to IEC 947-1 and 947-3.

### SAFETY:

- Do not exceed voltage rating on the label located on the side of the instrument housing.
- Always disconnect power before changing signal and power connections.
- Do not use this instrument on a work bench without its case for safety reasons.
- Do not operate this instrument in flammable or explosive atmospheres.
- Do not expose this instrument to rain or moisture.

### EMC:

- Whenever EMC is an issue, always use shielded cables.
- Never run signal and power wires in the same conduit.
- Use signal wire connections with twisted-pair cables.
- Install Ferrite Bead(s) on signal wire close to the instrument if EMC problems persist.

### MOUNTING

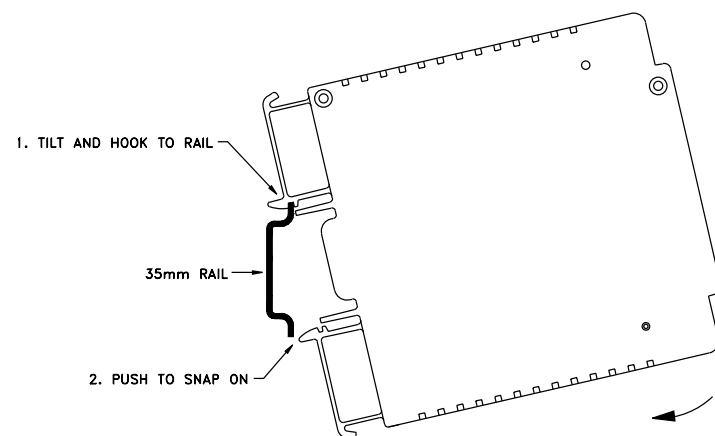

To install unit onto DIN Rail:

- Tilt unit, position mounting slot onto DIN Rail, as shown.
- Push unit towards DIN Rail and it will snap into place.

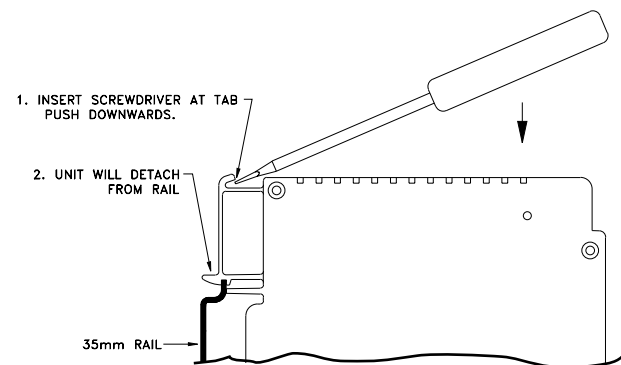

To remove unit from DIN Rail:

- Insert flat screw-driver into tab and push downwards.
- Unit will detach from DIN Rail.

### DIMENSIONS

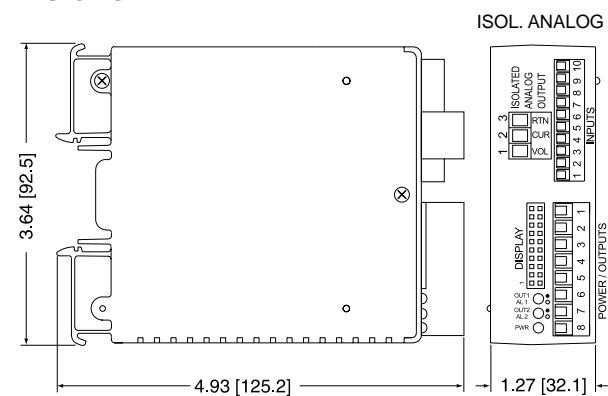

### WIRING

Wire the instrument according to the figure shown below.



**Warning: Do not connect ac power to your device until you have completed all input and output connections. This device must only be installed by a specially trained electrician with corresponding qualifications. Failure to follow all instructions and warnings may result in injury!**

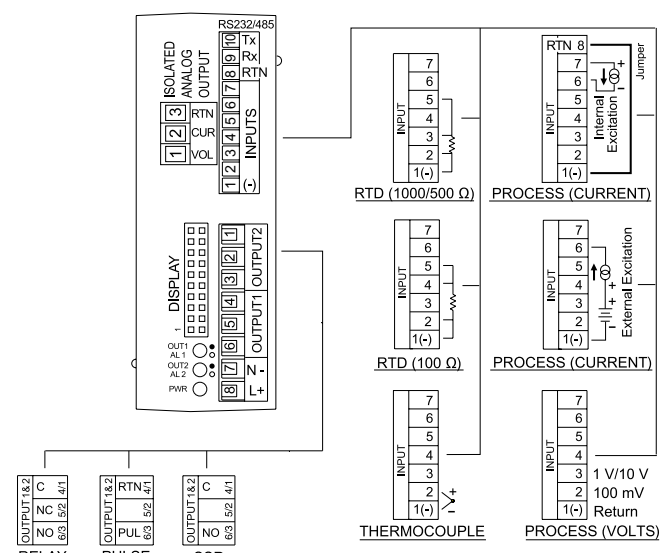

Note: Output 2 is for -AL Limit Alarm Option only.

Connect the main power connections as shown in the figure below.

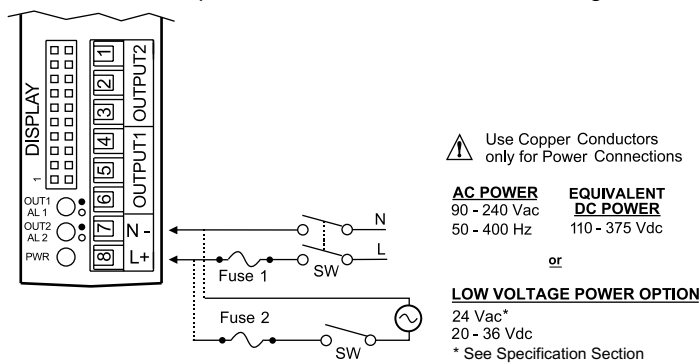

FUSE	Connector	Output Type	For 115Vac	For 230Vac	DC
FUSE 1	Power	N/A	100 mA(T)	63 mA(T)	63 mA(T)
FUSE 2	Power	N/A	N/A	N/A	400 mA(T)

### CONFIGURATION



The following steps for configuring your device are explained by using the optional Remote Programmer Display (iDRP), you may also configure your device through the Communication option (-C24).

#### Button Functions in Configuration Mode

	<ul style="list-style-type: none"> <li>To enter the Menu, the user must first press .</li> <li>Use this button to advance/navigate to the next menu item. The user can navigate through all the top level menus by pressing .</li> <li>While a parameter is being modified, press this button to escape without saving the parameter.</li> </ul>
	<ul style="list-style-type: none"> <li>Press the up  button to scroll through "flashing" selections. When a numerical value is displayed press this key to increase value of a parameter that is currently being modified.</li> <li>Holding the  button down for approximately 3 seconds will speed up the rate at which the set point value is incremented.</li> <li>In the Run Mode pressing  causes the display to flash the PEAK value – press again to return to the Run Mode.</li> </ul>
	<ul style="list-style-type: none"> <li>Press the down  button to go back to a previous Top Level Menu item.</li> <li>Press this button <b>twice to reset the monitor</b> to the Run Mode.</li> <li>When a numerical value is flashing (except set point value) press this button to scroll digits from left to right allowing the user to select the desired digit to modify.</li> <li>When a set point value is displayed press this button to decrease value of a set point that is currently being modified. Holding the  button down for approximately 3 seconds will speed up the rate at which the setpoint value is decremented.</li> <li>In the Run Mode pressing  causes the display to flash the Valley value - press again to return to the Run Mode.</li> </ul>
	<ul style="list-style-type: none"> <li>Press this button to access the submenus from a Top Level Menu item.</li> <li>Press this button to store a submenu selection or after entering a value — the display will flash a <b>S E R V</b> message to confirm your selection.</li> <li>Press this button to reset flashing PEAK or VALLEY value.</li> </ul>



Reset: Except for Alarms, modifying any settings of the menu configuration will reset the controller prior to resuming Run Mode.

### DISPLAY ABBREVIATIONS

SP2	Set Point 2 Value	CNFG	Configuration Menu
INPt	Input Type Menu	t.c	Thermocouple Input
k. . . J	Thermocouple Type	Rtd	RTD Input
385.2	RTD Curve and Connection Type (2, 3, 4-Wire)	100 _	100 _/500 _/1000 _
392.4		1000	RTD Sensor
PROC	Process Input		
0 - 0.1	100 mV Input Voltage	0 - 1.0	1 V Input Voltage
0 - 20	20 mA Input Current	0 - 10	10 V Input Voltage
RdG	Reading Configuration	dEC	Decimal Point
F.FFF. . . FFFF	Decimal Point Position	FLtR	Filter Constant
TEMP	Unit of Temperature	C	Celcius
F	Fahrenheit		
0001.. .0128	Filter Constant Value	IN.Rd	Input/Reading Scale and Offset Menu
IN 1	Input 1	IN 2	Input 2
Rd 1	Reading 1	Rd 2	Reading 2
ANLG	Analog Output		
VoLt	Voltage Output	CURR	Current Output
Out.1	Output 1	Rd 1	Reading 1
Out.2	Output 2	Rd 2	Reading 2
ALR2	Alarm 2 Menu	AbSo	Absolute Mode
dEV	Deviation Mode	Ltch	Latched Mode
UNLt	Unlatched Mode		
N.o.	Normally Open	N.c.	Normally Closed
ActV	Active Type	AboV	Active Above
bELo	Active Below	Hi.Lo	Above High/Below Low
bANd	Above or Below Band		
ALR.L	Alarm Low Value	ALR.H	Alarm High Value
Id	ID Code Menu	CH.Id	Change ID Code
FULL	Full ID	SP.Id	Set Point ID
COMM	Communication Option*	NONE	Communication is Not Installed
C.PAR	Communication Parameters	bAUd	Baud Rate
PRtY	Parity	odd	Odd
EVEN	Even	No	No
dAtA	Data Bit	7.bit	7 Data Bit
8.bit	8 Data Bit	StOP	Stop Bit
1.bit	1 Data Bit	2.bit	2 Stop Bit
bus.F	Bus Format	M.bus	Modbus Protocol
LF	Line Feed	ECHO	Echo
StNd	Communication Standard	232C	RS-232
485	RS-485	ModE	Data Flow Mode
CMd	Command Mode	CoNt	Continuous Mode
SEPR	Data Separation Character	SPCE	Space
cR	Carriage Return	dAt.F	Data Format
stAt	Alarm Status	RdNG	Transmit Reading Value
PEAk	Transmit Peak Value	GROS	Transmit Gross Value
UNit	Units of Measurement	AddR	Multipoint Address
tR.tM	Transmit Time Interval		
COLR	Display Color Selection	N.CLR	Normal Color Display
2.CLR	Alarm 2 Color Display	REd	Display Color is Red
AMbR	Display Color is Amber	GRN	Display Color is Green
ENBL	Enable	dSbL	Disable
ERRo	Error	+ OL	Input (+) Overload
+ OPN	Input (+) Open	- OPN	Input (-) Open

\*For abbreviations of Communication Option see Communication Manual