

FP7001/N

Paddlewheel Flowsensor

Operator's Manual

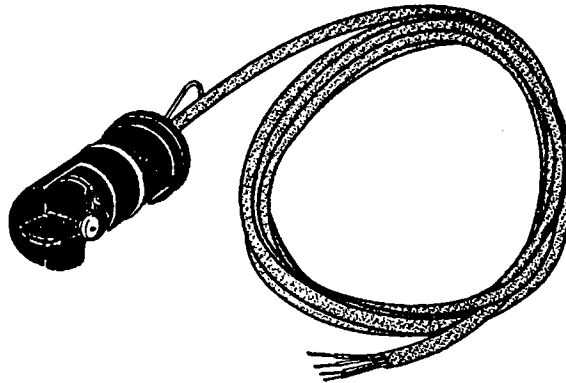

 **Newport Electronics, Inc.**

NOTES

SECTION 1 GENERAL DESCRIPTION

The FP7001/N paddlewheel flow sensor is ideal for economical monitoring of typical industrial water flows — from hard-to-handle corrosive aqueous solutions to high purity fluids. The FP7001/N uses a paddlewheel-like rotor whose motion is converted into a high-level square wave pulse output by an open collector Hall Effect sensor. Pulse amplitudes from 5 to 18V are possible, depending on input power. When powered by the FPW-5, 5VDC wall socket converter, the FP7001/N has a TTL level pulse output which can be used with a variety of pulse input flow indicators, signal conditioners and controllers.

A complete flow measurement system consists of the flow sensor, the installation fitting and a readout device. The FP7001/N has polypropylene, 316SS, and Viton wetted parts. The schedule 40 PVC tee fittings are supplied with a PVC locking nut, and the galvanized iron tee fittings are supplied with a brass locking nut to provide a secure metal-to-metal mounting to the threaded brass insert.

SECTION 2 INSTALLATION

2.1 UNPACKING

Remove the Packing List and verify that you have received all equipment. If you have any questions about the shipment, please call the Newport Customer Service Department at 1-800-NEWPORT or (714) 540-4914.

When you receive the shipment, inspect the container and equipment for any signs of damage. Note any evidence of rough handling in transit. Immediately report any damage to the shipping agent.

NOTE

The carrier will not honor any claims unless all shipping material is saved for their examination. After examining and removing contents, save packing material and carton in the event reshipment is necessary.

2.2 IMPORTANT CONSIDERATIONS BEFORE INSTALLATION

CAUTION

THE FP7001/N PADDLEWHEEL FLOWSENSOR IS NOT EXPLOSION-PROOF, NOR IS IT INTRINSICALLY SAFE. IT IS NOT TO BE USED FOR FLAMMABLE OR HAZARDOUS LIQUIDS, NOR CAN IT BE USED IN HAZARDOUS AREAS.

The FP7001/N is intended for use with water and other low viscosity liquids ONLY; it can NOT be used with oils and other viscous materials. They can be used with non-flammable, non-hazardous liquids up to 5 centipoise viscosity, but field calibration is recommended for accurate measurements.

The FP7001/N is a bi-directional device; flow in the forward or reverse direction provides the same pulse output. The FP7001/N will only measure flowrates down to one fps velocity; this corresponds to the following minimum GPM flowrates: ¾" pipe = 1.5 GPM; 1" = 3 GPM; 1½" = 4.5 GPM; 1½" = 6.5 GPM; 2" = 10.5 GPM; 2½" = 15 GPM; 3" = 23 GPM.

It is important to note that most process water contains dissolved minerals. If the flowsensor is repeatedly exposed to process water and then the line is allowed to dry, these dissolved minerals will deposit onto the FP7001/N and will inhibit the low flowrate operation of the sensor. If this occurs, cleaning of the sensor is recommended.

CAUTION

WATER HAMMER AND SURGES CAN BE DAMAGING TO ANY FLOWMETER AND MUST ALWAYS BE AVOIDED.

WATER HAMMER OCCURS WHEN A LIQUID FLOW IS SUDDENLY STOPPED AS WITH QUICK CLOSING AND SOLENOID OPERATED VALVES. SURGES OCCUR WHEN FLOW IS SUDDENLY BEGUN, AS WHEN A PUMP IS TURNED ON AT FULL POWER OR A VALVE IS QUICKLY OPENED.

LIQUID SURGES ARE PARTICULARLY DAMAGING TO FLOWMETERS IF THE PIPE IS ORIGINALLY EMPTY. TO AVOID DAMAGING SURGES, FLUID LINES SHOULD REMAIN FULL (IF POSSIBLE) AND PUMPS SHOULD BE BROUGHT UP TO POWER AND VALVES OPEN SLOWLY. IN ADDITION, TO AVOID BOTH WATER HAMMER AND SURGES, A SURGE CHAMBER SHOULD BE INSTALLED.

2.3 FLOWMETER INSTALLATION

The FP7001/N can be mounted in vertical or horizontal pipe runs; however, the pipe must be full of liquid for proper readings. Thus, the sensor should not be mounted in vertical pipe where the liquid flows down, since the pipe may not always be full in this situation. Refer to Figures 2-1 and 2-2.

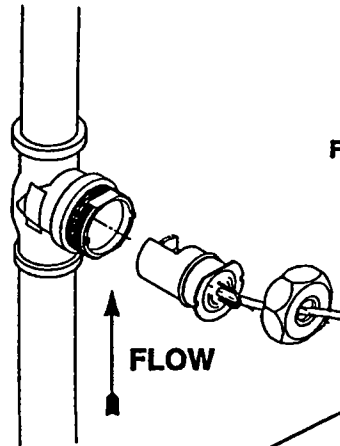

Figure 2-1. Horizontal Mounting Position

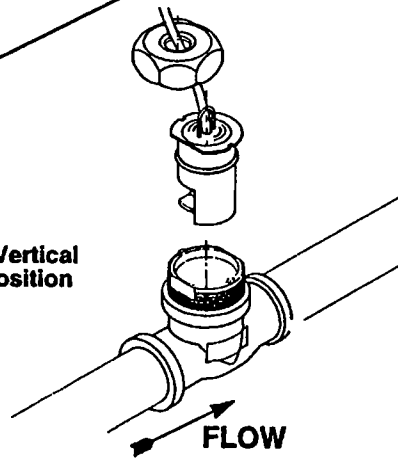

Figure 2-2. Vertical Mounting Position

The FP7001/N should not be mounted at the bottom of the pipe (the 6 o'clock position) because this is where sediment in the liquid will tend to accumulate. The best mounting location is at or near the 12 o'clock position, so long as bubbles are not present in the liquid. The 3 o'clock and 9 o'clock positions are also acceptable. In an upward flowing vertical pipe, the flowsensor can be mounted anywhere around the pipe.

As with many flowmeters, the FP7001/N requires a fully developed turbulent flow profile in order to provide accurate readings. To insure this, a length of straight pipe run before and after the flowmeter is required. The amount of upstream straight pipe run required depends upon the type of obstruction which is immediately upstream of the flowsensor. See Table 2-1 for specific requirements. Downstream of the flowsensor, in all situations, only 5 diameters of straight pipe run are required, regardless of the downstream obstruction.

TABLE 2-1

UPSTREAM OBSTRUCTION	STRAIGHT PIPE RUN REQUIRED UPSTREAM OF PADDLEWHEEL SENSOR
Concentric reducer	15 pipe diameters
One elbow	20 pipe diameters
2 elbows, in same plane	25 pipe diameters
2 elbows in two planes or one expansion	40 pipe diameters
Valves, pumps* same plane	at least 50 pipe diameters, prefer sensor mounted upstream

* Oscillating or reciprocating pumps, which produce flow and pressure pulses in the flowstream, are not recommended for use with the FP7001/N flowsensor.

NOTE: if you do not have the proper amount of straight pipe run available at your desired installation location, it is recommended to use flow straighteners to decrease the required straight run.

The paddlewheel must be aligned with the fluid flow; the installation fitting is supplied with an alignment tab which mates with a flat on the base of the paddlewheel sensor to insure proper sensor alignment. When using the PVC installation fittings, it is critical that the cap of the sensor is threaded onto the mating fitting **HAND TIGHT ONLY**; use of pipe wrenches, etc. on the plastic cap can lead to damage to the cap and/or the installation fitting.

The FP7001/N has magnets installed in the rotating paddles; these magnets will tend to attract rust from the flowing fluid. Thus, it is **NOT** recommended to install the FP7001/N in pipes which under typical conditions contain rust, such as in cast iron, black iron, carbon steel and other iron pipes (galvanized pipe has been treated to resist rust). In situations where rust can not be avoided, it is recommended to install a fine magnetic filter at least 50 pipe diameters upstream from the FP7001/N and to periodically shut down the line and remove the sensor from the installation fitting for cleaning.

2.4 WIRING

NOTE

To insure proper hook-up to your indicating device, the paddles of the FP7001/N can be spun in the open air by blowing onto them before the sensor is installed into the installation fitting.

This is particularly important where the pipeline can not be conveniently shut down and the sensor removed after installation.

The FP7001/N has the following connections:

BLACK GROUND (for both pulse output and for DC power input)
RED 5-18VDC (power input)
WHITE FREQUENCY SIGNAL OUTPUT (high)
GREEN No Connection

For systems without an internal pull-up resistor, a nominal 10,000Ω, ¼ Watt resistor must be installed between the red and white wires. If 5VDC power is supplied, the output signal will be TTL level, which is compatible with a wide variety of computer interface equipment that accepts TTL level pulse input.

Up to 300 feet of additional wire can be spliced onto the sensor wires in the field.

SECTION 3 MAINTENANCE

Except for intermittent removal of the sensor from the line for cleaning, there is no routine maintenance for the FP7001/N flowsensor.

SECTION 4 CALIBRATION

The K-factor, or pulses per gallon output of your FP7001/N sensor varies with the FP7001/N installation fitting which was purchased with it. The K-factor is labeled on the fitting.

SECTION 5 SPECIFICATIONS (SUBJECT TO CHANGE)

ACCURACY: +2% of full scale
REPEATABILITY: +1% of full scale
POWER: 5 to 18VDC @ 10 mA maximum

WETTED MATERIALS:

FP7001/N sensor: polypropylene body (PVDF optional), PVDF paddle, Viton O-ring, 316SS shaft. Galvanized iron tee includes brass insert and locking nut. PVC tee has PVC insert and locking nut.

MAX. RECOMMENDED

FLUID VISCOSITY: 5 centipoise

FLUID TEMPERATURE/ PRESSURE RANGE:

do not exceed the maximum ratings of your piping. Depending on the material of the fitting, the operating temperature/pressure may be limited by your piping, and not by the sensor. For all PVC tee fittings, do not exceed 150 PSIG @ 80°F (27°C), 100 PSIG @ 100°F (38°C), 60 PSIG @ 120°F (49°C), 30 PSIG @ 140°F (60°C), due to the insert in the tee. FP7000 sensor: 32° to 80°F (0° to 26°C) up to 150PSIG; max pressure decreases 1.1 PSIG per each 1°F about 80°F for a max. temperature of 200°F at 18 PSIG max.

SENSOR

FP7001/N Polypropylene body/316SS shaft

INSTALLATION FITTINGS (includes locking nut)

PVC, SCHED. 40 (PART NUMBER)	GALVANIZED IRON (PART NUMBER)	PIPE SIZE	RANGE (GPM)
FP7007/N	FP7007-GI/N	¾"	2-30
FP7010/N	FP7010-GI/N	1"	3-50
FP7012/N	FP7012-GI/N	1½"	5-90
FP7015/N	FP7015-GI/N	1½"	7-125
FP7020/N	FP7020-GI/N	2"	11-205
FP7025/N	FP7025-GI/N	2½"	15-285
FP7030/N	FP7030-GI/N	3"	25-460

Other fitting materials available. Consult Flow Engineering.

For technical or application assistance please call:

Newport Electronics, Inc.
2229 South Yale Street • Santa Ana, CA • 92704-4426 • TEL: (714) 540-4914,
(800)-NEWPORT • FAX: (714) 546-3022

Newport Technologies Inc.
976 Bergar • Laval (Quebec) • H7L 5A1 • Canada • TEL: (514) 335-3183
FAX: (514) 856-6886

Newport Electronics Ltd.
Unit 25 Swannington Road • Cottage Lane Industrial Estate • Broughton Astley
Leicestershire • England • LE9 6TU • TEL: 44 (1455) 285998 • FAX: 44 (1455) 285604

Newport Electronics B. V.
Postbus 8034 • 1180 LA Amstelveen • The Netherlands • TEL: 31 (20) 6418405
FAX: 31 (20) 6434643

Newport Electronics Spol S.R.O.
Ostravska 767 • 733 01 Karvina • Czech Republic • TEL: 42 (69) 6311899
FAX: 42 (69) 6311114

Newport Electronics GmbH
Daimlerstrasse 26 • D-75392 Deckenpfronn • Germany • TEL: 49 (07056) 3017
FAX: 49 (07056) 8540

Newport Electronics S.A.R.L.
9 rue Denis Papin • 78190 Trappes • France • TEL: 33 (1) 30.62.14.00
FAX: 33 (1) 30.69.91.20

In Mexico
TEL: (95) 800-NEWPORT



Newport Electronics, Inc.